

Extraneous Load Factors

Equation: $\sigma_{max} \geq (A)F_x + (B)F_y + (C)F_z + (D)M_x + (E)M_y + (F)M_z$

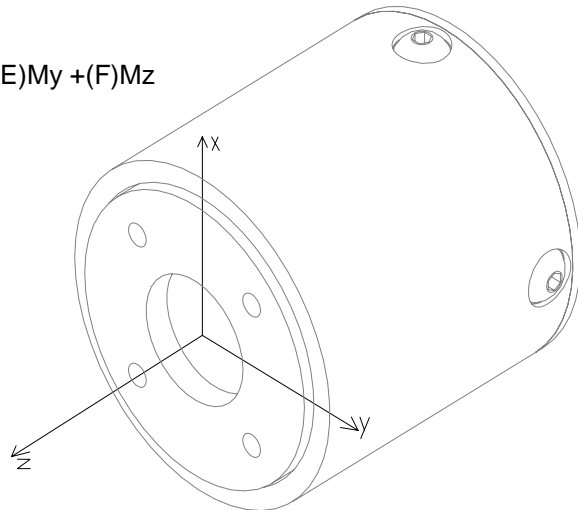

Material: Aluminum 2024-T4 (*AL)

Model #	Capacity	A	B	C	D	E	F
TFF400	5 in-oz	2959	2959	125	654	654	6112
	10 in-oz	2025	2025	93	529	529	3677
	20 in-oz	1398	1398	79	429	429	2767
	50 in-oz	1158	1158	52	281	281	2294
	100 in-oz	735	735	30	155	155	1360
	160 in-oz	468	468	22	117	117	737
	400 in-oz	267	267	15	73	73	422
TFF400	1,000 in-oz	143	143	12	52	52	197
	100 in-lb	108	108	12	55	55	149
	200 in-lb	87	87	10	48	48	77
	500 in-lb	44	44	5	26	26	27

σ_{max} **Table**

Material	Static Load (=60% Y.S.)	Fatigue (Non Reversing Loads)	Fatigue (Full Reversing Loads)
2024-T4/T351	28,000	18,000	15,000

*Value is 75% of Fatigue Strength based on 10-20 x 10⁶ cycles and allow for factors that influence Fatigue such as surface finish, stress concentrations, corrosion, temperature and other variables for the production of the transducer, for infinite Fatigue Life (100 x 10⁶) use 75% of values shown.

This documentation was generated and completed to the best ability of FUTEK's Engineering Team using FEA Analysis, Empirical data and Multiple Testing Simulations. The information and recommendations on this document are presented in good faith and believed to be correct however, FUTEK Advanced Sensor Technology makes no representations or warranties as to the completeness or accuracy of the information.