

Input Ranges From $\pm 0.25G$ to $\pm 2G^\circ$ Rugged, High Precision, Low Cost, Dual-Ended Power Input Accelerometer

The Jewell **Emerald Series** accelerometer is a low cost, high precision sensor designed with higher accuracy than comparable MEMS devices. Applications include robotics, construction equipment, industrial measurement and control, and precision machining. All Emerald Series accelerometers are RoHS compliant.

Features

- Extremely Rugged
- Lower Cost than traditional Force-Balanced Accelerometers
- High Accuracy
- Greater Precision than MEMS Technologies
- ± 5 V DC Output
- Dual-Ended Power Input
- RoHS Compliant

Applications

- Aerospace
- Military
- Robotics
- Academic Research
- Wind Turbine Controls
- Track Monitoring and Testing
- Vehicle Wheel Alignment



Outline Diagram

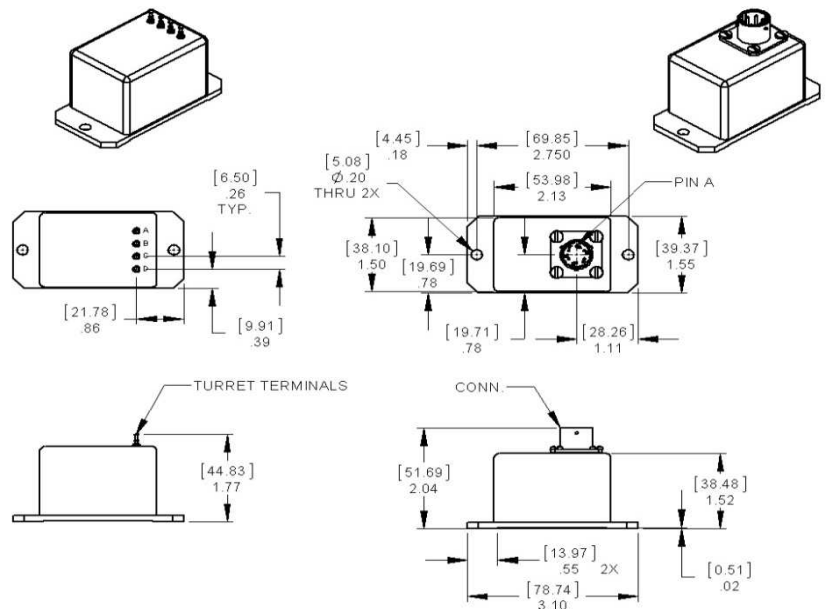

Dimensions in inches [mm]

Pin Out

Pin Option		Connector Option	
A	Input Power	A	Input Power
B	Power/Signal Common	B	Power/Signal Common
C	N/C	C	Return
D	Signal	D	Signal
		E	N/C
		F	N/C

Performance Specifications

STATIC/DYNAMIC

Input Range, G:	±0.25	±0.5	±1	±2
Full Range Output (FRO -Note 1) VDC ±0.5%:	±5	±5	±5	±5
Nonlinearity (Note 2) % FRO maximum:	0.02	0.02	0.05	0.05
Scale Factor, Volts/g, nominal:	20.0	10.0	5.0	2.5
Scale Factor Temp. Sensitivity (SFTS), PPM /°C maximum:	100	100	100	100
Bandwidth (-3 dB), Hz nominal:	5.0	5.0	5.0	5.0
Output Axis Misalignment, ° maximum:	0.50	0.50	0.50	0.50
Pendulous Axis Misalignment, ° maximum:	0.50	0.50	0.50	0.50
Resolution and Threshold, µg maximum:	3.5	3.5	3.5	3.5

ELECTRICAL

Number of Axes:	1
Input Voltage Range, (VDC):	±12 to ±18
Input Current, mA, max:	40
Output Impedance, Ohms, nom:	10
Noise, Vrms, maximum:	0.002

ENCLOSURE

Seal:	IP65
-------	------

ENVIRONMENTAL

Operating Temp Range:	-55°C to +85°C
Storage Temp Range:	-60°C to +90°C
Shock:	500g, 1 msec, ½ sine

Notes:

Note 1: Full Range is defined "from negative full input acceleration to positive full input acceleration."

Note 2: Nonlinearity is specified as deviation of output referenced to theoretical sine function value, independent of misalignment.

Note 3: Full Resolution is achieved with noise reduction techniques.

Custom Capabilities

- ±15V bipolar input option available
- Pigtail and Connector alternative options available
- Custom ranges and bandwidths available

How to Order

Connector Version

Model #	Part #
SMAC-D-0.25	02550354-001
SMAC-D-0.5	02550354-002
SMAC-D-1	02550354-003
SMAC-D-2	02550354-004

Pin Version

Model #	Part #
SMAP-D-0.25	02550353-001
SMAP-D-0.5	02550353-002
SMAP-D-1	02550353-003
SMAP-D-2	02550353-004