

CRH03 Series Technical Datasheet



High Performance Analogue Angular Rate Sensor

CRH03

Housed Version



CRH03

OEM Version



Features

- Fibre Optic Gyro (FOG) like performance
- Small size
- Proven and Robust silicon MEMS VSG3Q^{MAX} vibrating ring structure with improved balancing
- Five rate ranges available: $\pm 10^\circ/\text{s}$, $\pm 25^\circ/\text{s}$, $\pm 100^\circ/\text{s}$, $\pm 200^\circ/\text{s}$ and $\pm 400^\circ/\text{s}$
- Low bias instability - $0.04^\circ/\text{hr}$ ($100^\circ/\text{s}$)
- Excellent angle random walk - $0.006^\circ/\sqrt{\text{hr}}$ ($100^\circ/\text{s}$)
- Low noise - $0.12^\circ/\text{s rms}$ ($100^\circ/\text{s}$)
- Precision analogue output
- High shock and vibration rejection
- Precise thermal compensation with non R version
- Approximately half noise reduction against previous model CRH02
- Warm-up drift reduction against previous model CRH02
- RoHS Compliant
- Low current compensation compared to CRH02

Applications

- Aerospace
- Platform Stabilisation
- Precision Surveying
- Maritime Guidance and Control
- Gyro-compassing and Heading Control
- Autonomous Vehicles and ROVs
- Rail Track monitoring
- Robotics
- Drilling Equipment and Guidance
- Inertial Measurement Units

1 General Description

The CRH03 provides an optimal solution when bias instability, angle random walk, and low noise levels are critical requirements. It uses Silicon Sensing's proven MEMS resonating structure along with an improved balancing technique that optimizes operation in the $\cos 2\theta$ vibrating mode. This mechanical design and operating mode make the CRH03 extremely robust and resistant to external vibrations.

The CRH03 OEM and OEM R versions are designed for integration without needing an enclosure. The standard OEM uses an internal thermistor to correct for scale factor changes as the magnet's field strength varies with temperature. The OEM R provides uncompensated raw output, allowing temperature compensation by the host system using the on-board temperature sensor or the MEMS resonant frequency itself as a temperature indicator.

If external calibration and compensation are preferred, the OEM R is the optimal choice. It replaces the thermistor with a fixed precision resistor. This requires the host to compensate for a larger scale factor error but benefits from using just one temperature source for compensation instead of the three effective sensors in the standard OEM - the thermistor, internal temperature sensor, and frequency output indicating MEMS temperature. During thermal transients, differing temperatures between these three measurements can cause temporary scale factor errors.

For multi-axis applications, the OEM versions of the CRH03 are available in three frequency ranges V, L, and M. This minimizes interference between axes. All frequency variants have identical functionality, performance, and interface. The available OEM variants and their frequency outputs are:

MEMS Type	Frequency Output
V-Type	<27.37 (kHz)
L-Type	27.37~27.83 (kHz)
M-Type	>27.83 (kHz)

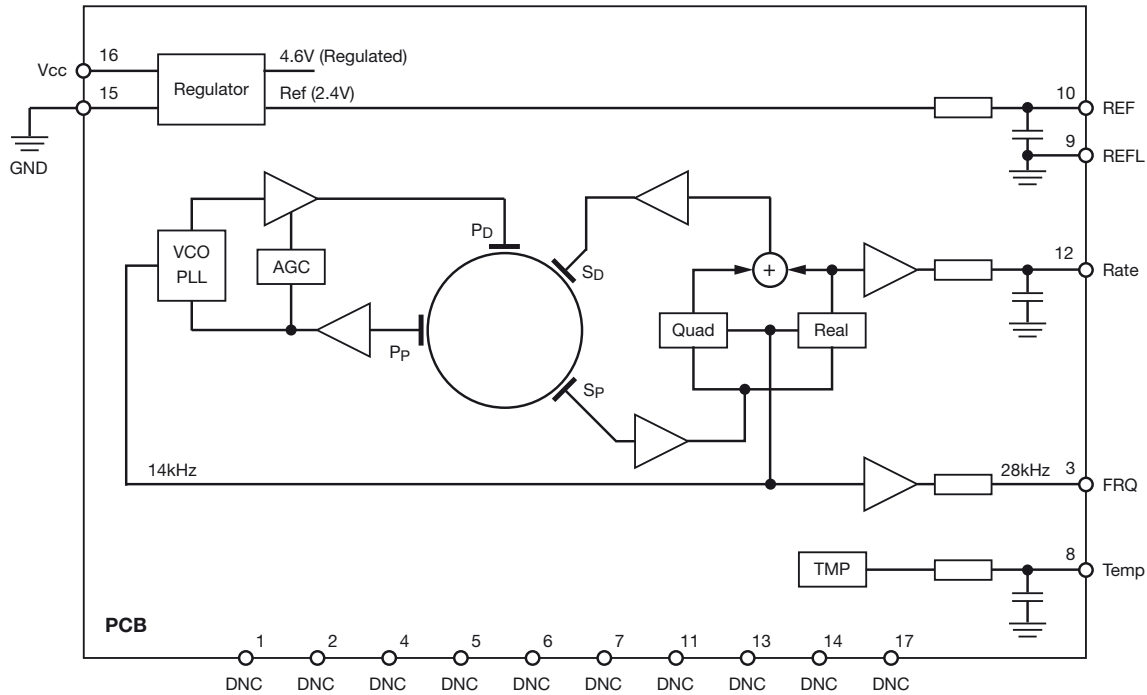

C.G.18916

Figure 1.1 CRH03 Functional Block Diagram

2 Ordering Information

For the housed version (includes accessory cable) use these part numbers:

Rate Range	Part Number
±10°/s	CRH03-010
±25°/s	CRH03-025
±100°/s	CRH03-100
±200°/s	CRH03-200
±400°/s	CRH03-400

For the OEM version use these:

Rate Range	Part Number		
	V frequency	L frequency	M frequency
±10°/s	CRH03-010UV	CRH03-010UL	CRH03-010UM
±25°/s	CRH03-025UV	CRH03-025UL	CRH03-025UM
±100°/s	CRH03-100UV	CRH03-100UL	CRH03-100UM
±200°/s	CRH03-200UV	CRH03-200UL	CRH03-200UM
±400°/s	CRH03-400UV	CRH03-400UL	CRH03-400UM

For the OEM R version (only available at 200 and 400°/s):

Rate Range	Part Number		
	V frequency	L frequency	M frequency
±200°/s	CRH03-200UVR	CRH03-200ULR	CRH03-200UMR
±400°/s	CRH03-400UVR	CRH03-400ULR	CRH03-400UMR

The OEM version does not include the accessory cable, if required order part PSD-02701001.

3 Mechanical Detail

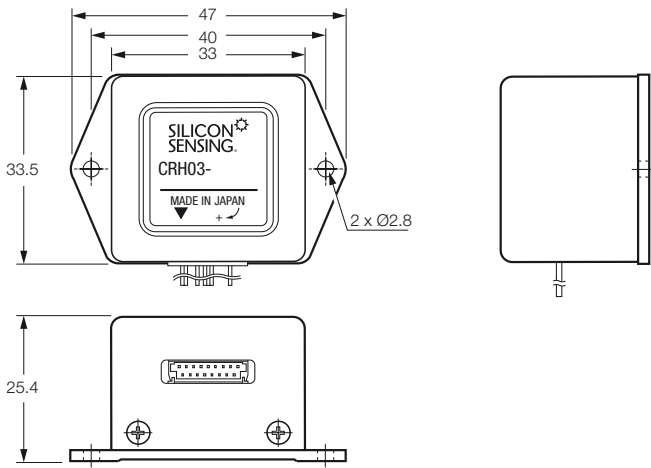

All dimensions in millimetres.

Figure 3.1 CRH03 (Housed Version) Overall Dimensions

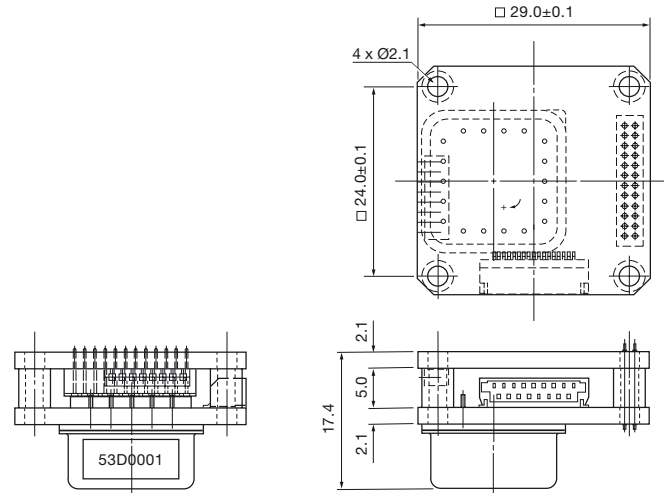

C.G. 18890

Figure 3.2 CRH03 (OEM Version) Overall Dimensions

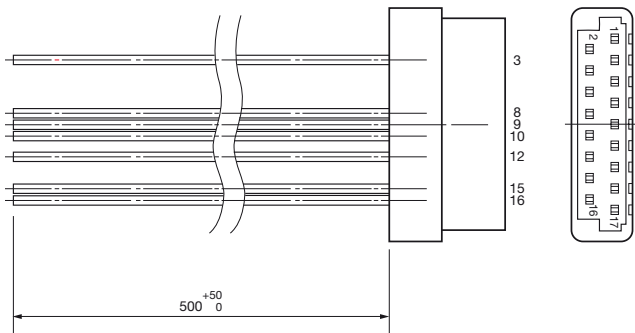

C.G. 18891

(Accessory cable is included only with the housed version of CRH03.)
FI-C3-A1-15000 is the female crimp pin on the accessory cable that mates with the male pin on the CRH03.

Figure 3.3 Accessory Cable

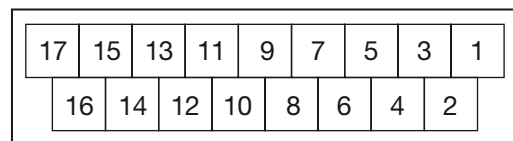

C.G. 18892

Mating connector part number: FI-W17S
Made by "Japan Aviation Electronics Industry, Ltd."
FI-C3-A1-15000 is the female crimp pin" on the accessory cable that mates with the male pin on the CRH03.

Figure 3.4 Connector Terminal Number (Mating Surface View)

CRH03 Series Technical Datasheet

High Performance Analogue Angular Rate Sensor



4 Specification

Unless stated otherwise, the following specification values assume $V_{dd} = 4.85$ to $5.25V$ and an ambient temperature of $+25^{\circ}C$. "Over temperature" refers to the temperature range $-40^{\circ}C$ to $+85^{\circ}C$.

Parameter		Minimum	Typical	Maximum	Notes
Characteristic					
Rate Range	CRH03-010	$\pm 10^{\circ}/s$			-
	CRH03-025	$\pm 25^{\circ}/s$			-
	CRH03-100	$\pm 100^{\circ}/s$			-
	CRH03-200	$\pm 200^{\circ}/s$			-
	CRH03-400	$\pm 400^{\circ}/s$			-
Scale Factor at $25^{\circ}C$	CRH03-010	199.0mV/ $^{\circ}/s$	200.0mV/ $^{\circ}/s$	201.0mV/ $^{\circ}/s$	-
	CRH03-025	79.6mV/ $^{\circ}/s$	80.0mV/ $^{\circ}/s$	80.4mV/ $^{\circ}/s$	-
	CRH03-100	19.9mV/ $^{\circ}/s$	20.0mV/ $^{\circ}/s$	20.1mV/ $^{\circ}/s$	-
	CRH03-200	9.95mV/ $^{\circ}/s$	10.0mV/ $^{\circ}/s$	10.05mV/ $^{\circ}/s$	-
	CRH03-400	4.975mV/ $^{\circ}/s$	5.00mV/ $^{\circ}/s$	5.025mV/ $^{\circ}/s$	-
Scale Factor Variation Over Temperature with respect to RT ($25^{\circ}C$)	CRH03-010	-	$\pm 0.15\%$	$\pm 0.5\%$ ($\pm 10\%$)	(For R versions)
	CRH03-025	-	$\pm 0.15\%$		
	CRH03-100	-	$\pm 0.3\%$ ($\pm 5\%$)		
	CRH03-200	-	$\pm 0.3\%$ ($\pm 5\%$)		
	CRH03-400	-	$\pm 0.3\%$ ($\pm 5\%$)		
Scale Factor Non-Linearity	CRH03-010 CRH03-025 CRH03-100 CRH03-200 CRH03-400	-	$\pm 0.02\%$	$\pm 0.05\%$	-
Bias at $25^{\circ}C$		-	-	$\pm 10mV$	With respect to REF
Bias Over Temperature with respect to RT ($25^{\circ}C$)	CRH03-010	-	$\pm 0.1^{\circ}/s$	$\pm 0.2^{\circ}/s$	-
	CRH03-025	-	$\pm 0.1^{\circ}/s$	$\pm 0.2^{\circ}/s$	-
	CRH03-100	-	$\pm 0.15^{\circ}/s$	$\pm 0.25^{\circ}/s$	-
	CRH03-200	-	$\pm 0.15^{\circ}/s$	$\pm 0.25^{\circ}/s$	-
	CRH03-400	-	$\pm 0.15^{\circ}/s$	$\pm 0.25^{\circ}/s$	-
Warm-up Drift at $25^{\circ}C$		-	10 $^{\circ}/hr$ (0.027 $^{\circ}/s$)	-	-
Angular Random Walk at $25^{\circ}C$	CRH03-010	-	0.005 $^{\circ}/\sqrt{hr}$	-	Section 8.7
	CRH03-025	-	0.006 $^{\circ}/\sqrt{hr}$	-	
	CRH03-100	-	0.006 $^{\circ}/\sqrt{hr}$	-	
	CRH03-200	-	0.008 $^{\circ}/\sqrt{hr}$	-	-
	CRH03-400	-	0.010 $^{\circ}/\sqrt{hr}$	-	-

CRH03 Series Technical Datasheet

High Performance Analogue Angular Rate Sensor



4 Specification Continued

Parameter		Minimum	Typical	Maximum	Notes
Characteristic					
Bias Instability at 25°C	CRH03-010	-	0.03°/hr	-	Section 8.8
	CRH03-025	-	0.04°/hr	-	
	CRH03-100	-	0.04°/hr	-	
	CRH03-200	-	0.05°/hr	-	-
	CRH03-400	-	0.10°/hr	-	-
Quiescent Noise	CRH03-010	-	0.050°/s rms	-	3~50Hz
	CRH03-025	-	0.050°/s rms	-	3~50Hz
	CRH03-100	-	0.12°/s rms	-	3~100Hz
	CRH03-200	-	0.12°/s rms	-	3~100Hz
	CRH03-400	-	0.12°/s rms	-	3~100Hz
Bandwidth	CRH03-010	-	50Hz	-	-
	CRH03-025	-	50Hz	-	-
	CRH03-100	-	100Hz	-	-
	CRH03-200	-	100Hz	-	-
	CRH03-400	-	100Hz	-	-
Reference Output		2.380V	2.400V	2.420V	With respect to REFL
Minimum Output Current		500µA	-	-	-
Temperature Sensor Scale Factor		-	-11.7mV/°C	-	-
Start Up Time		-	-	750ms	-
Physical					
Mass (Housed Version)		-	42 grams	-	-
Mass (OEM Version)		-	18 grams	-	-
Cross Axis Sensitivity		-	-	3%	-
Environmental					
Temperature (Operating)		-40°C	-	85°C	-
Temperature (Storage)		-55°C	-	100°C	-
Humidity		-	-	95%	Non-condensing
Linear Acceleration Sensitivity		-	0.02°/s/g	-	-
Shock (Operating)		-	-	95g x 6ms	-
Shock (Powered Survival)		-	-	1000g x 1ms	-
Vibration Rectification Error		-	0.002°/s/g ² rms	-	10-2000Hz 10g rms
Vibration Induced Noise		-	0.01°/s rms/g ² rms	-	10-2000Hz 10g rms
MTTF		-	70000hr	-	-

4 Specification Continued

Parameter	Minimum	Typical	Maximum	Unit	Notes
Electrical					
Supply Voltage (Functional)	4.75	-	5.25	V	Section 8.1
Supply Voltage (Full Specification)	4.85	-	5.25	V	
Current Consumption	-	30	40	mA	-

5 Absolute Maximum

Parameter	Minimum	Maximum
Electrical		
Supply Voltage	-	6.0V
ESD Protection	-	2kV HBM

6 Interface

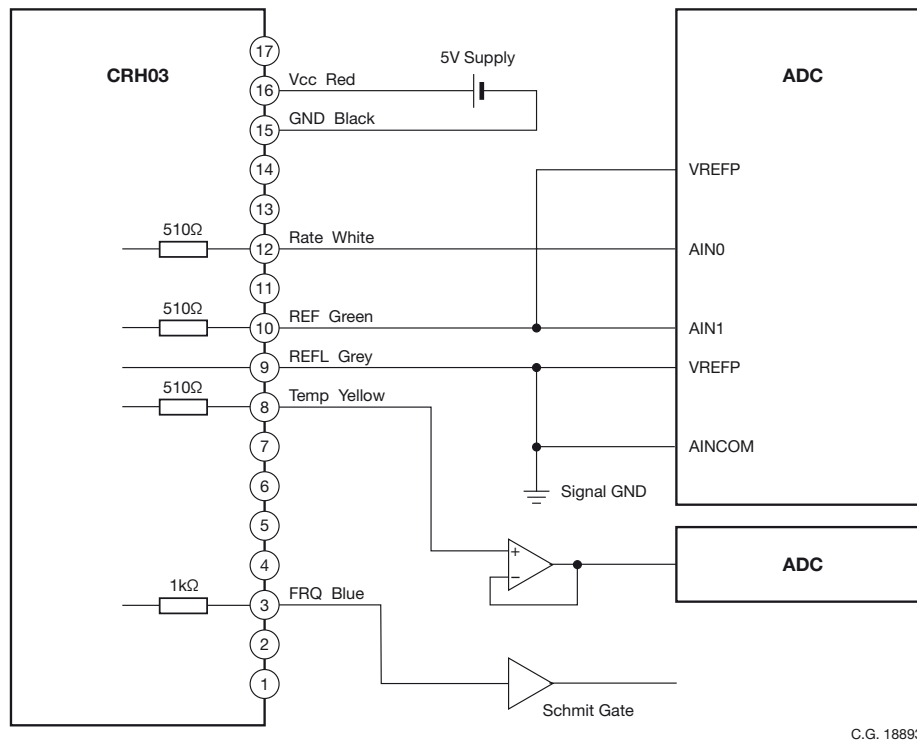

Figure 6.1 Recommended Peripheral Connection

6 Interface Continued

Pin Number	Pin Name	Signal Direction (I/O)	Function
3	FRQ	Output	Second harmonic resonating ring frequency output
8	Temp	Output	Temperature output with respect to REF
9	REFL	-	Reference Low voltage
10	REF	Output	Reference voltage datum for Rate, Temp
12	Rate	Output	Rate voltage with respect to REF
15	GND	-	Power ground
16	Vcc	-	Power supply to sensor
1, 2, 4, 5, 6, 7, 11, 13, 14, 17	DNC	-	Do not connect (SSS internal use)

6.1 Auxiliary Output Signals

Parameter	Minimum	Typical	Maximum	Notes
Frequency				
Resonating Ring Frequency	27kHz	28kHz	29kHz	Output impedance 1kΩ
Frequency Temperature Coefficient	-0.9Hz/°C	-0.80Hz/°C	-0.7Hz/°C	-
Temperature				
Temperature Sensor Offset at 0°C	-	-0.536V	-	With respect to REF output impedance 510Ω
Temperature Sensor Offset at 25°C	-	-0.830V	-	With respect to REF output impedance 510Ω
Temperature Sensor Scale Factor	-12.60mV/°C	-11.77mV/°C	-11.00mV/°C	Output impedance 510Ω

Note 1: The angle random walk is the value derived at the intercept of the $- \frac{1}{2}$ tangent on the Allan Variance plot and the 1 second correlation point (τ) divided by 60.

Note 2: The bias instability is the value at the minimum part of the Allan Variance plot, usually between 10s and 100s.

Note 3: The product must not be subjected to temperatures outside the recommended storage temperature range at any time.

Note 4: CRH03 is a precision measurement instrument. Do not drop onto a hard surface from a height exceeding 200mm.

7. Typical Performance Characteristics

This section shows the typical performance of CRH03, supplied with a 5.0V supply unless stated otherwise.

7.1 Bias Characteristics

This section shows typical bias variation over temperature with respect to the bias at +25°C.

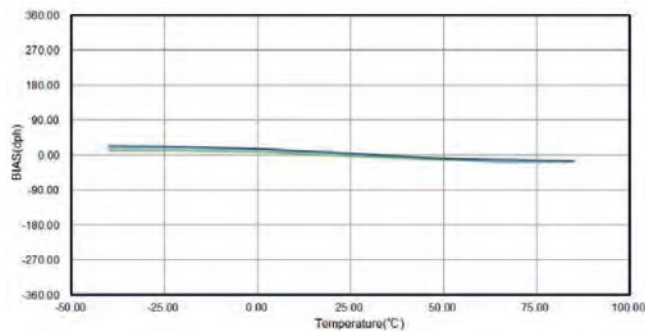

Figure 7.1 CRH03-010 Bias Performance (w.r.t. 25°C)

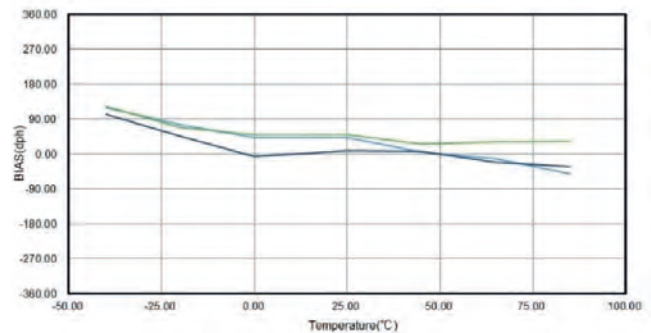

Figure 7.4 CRH03-200 Bias Performance (w.r.t. 25°C)

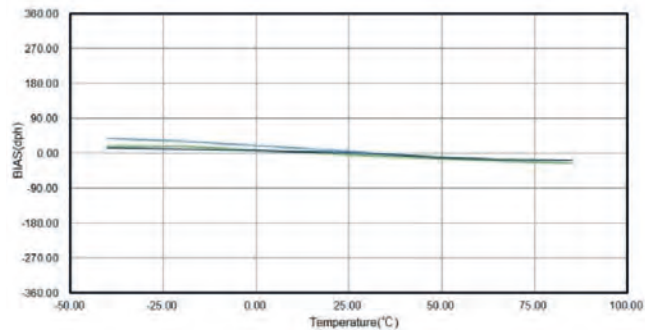

Figure 7.2 CRH03-025 Bias Performance (w.r.t. 25°C)

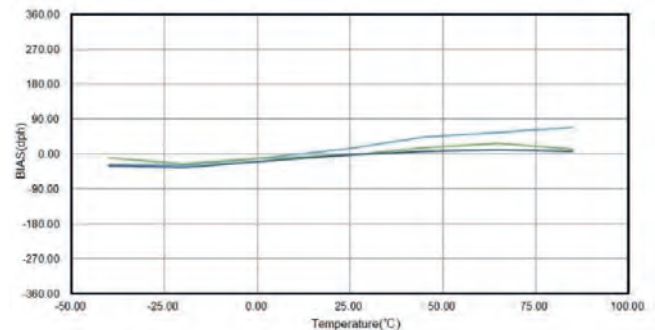

Figure 7.5 CRH03-400 Bias Performance (w.r.t. 25°C)

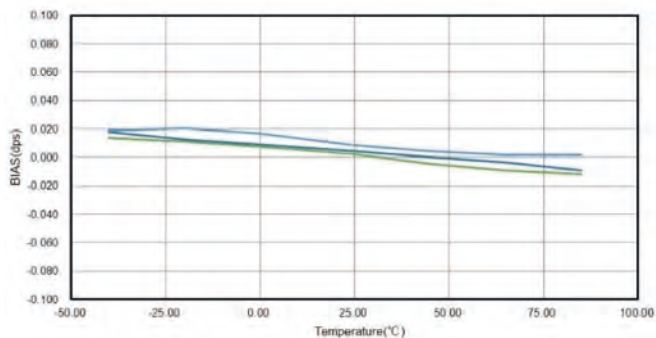

Figure 7.3 CRH03-100 Bias Performance (w.r.t. 25°C)

7.2 Scale Factor Characteristics

This section shows the typical scale factor variation over temperature with respect to the scale factor at +25°C

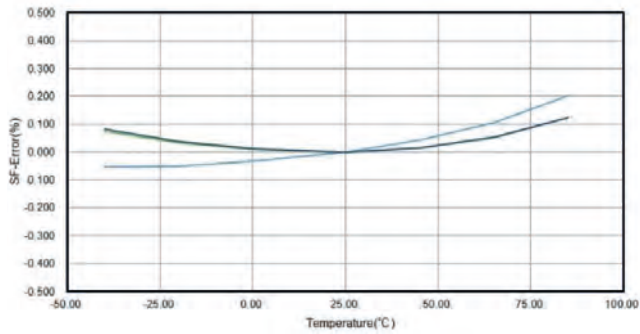

Figure 7.6 CRH03-010 SF Performance (w.r.t. 25°C)

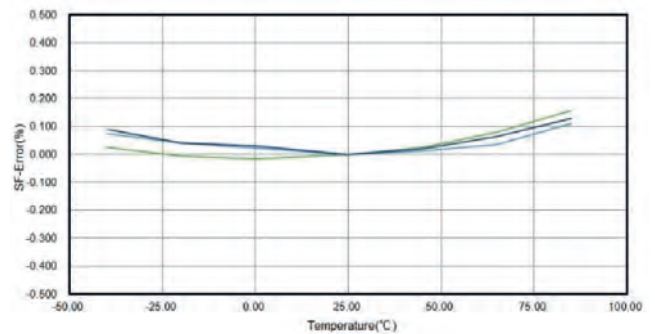

Figure 7.9 CRH03-200 SF Performance (w.r.t. 25°C)

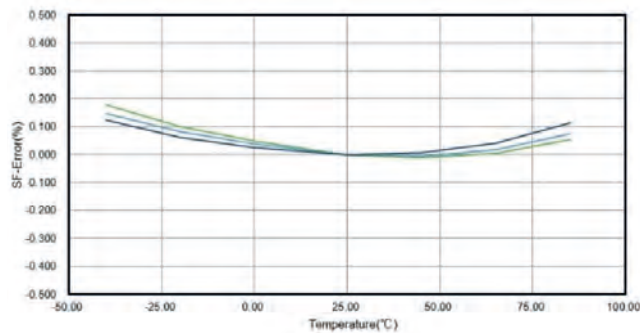

Figure 7.7 CRH03-025 SF Performance (w.r.t. 25°C)

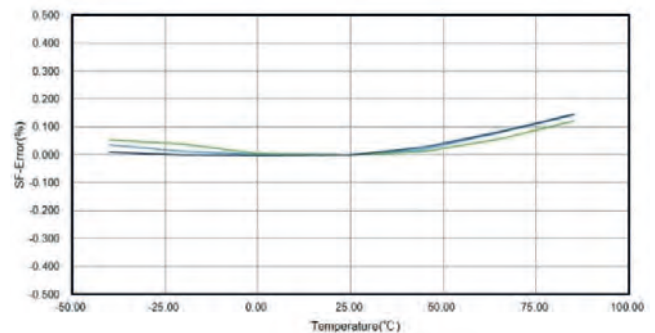

Figure 7.10 CRH03-400 SF Performance (w.r.t. 25°C)

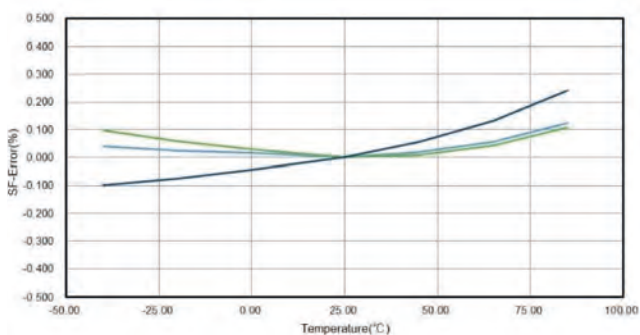

Figure 7.8 CRH03-100 SF Performance (w.r.t. 25°C)

7.3 Reference Performance Data for Allan Variance

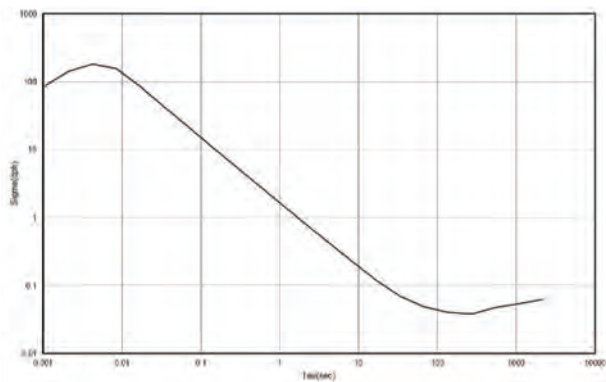

Figure 7.11 CRH03-010 Allan Variance Performance (w.r.t. 25°C)

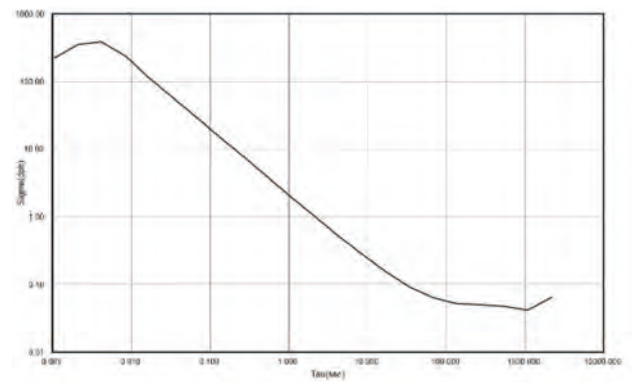

Figure 7.14 CRH03-200 Allan Variance Performance (w.r.t. 25°C)

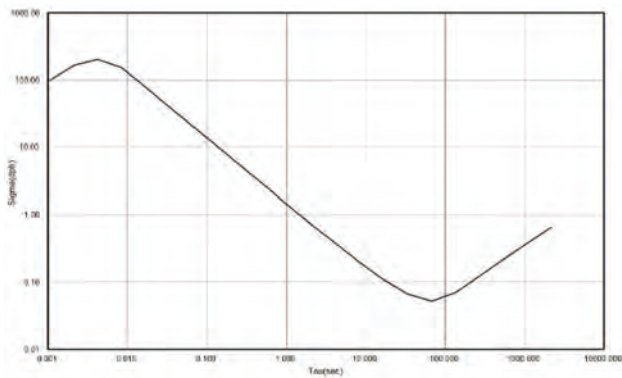

Figure 7.12 CRH03-025 Allan Variance Performance (w.r.t. 25°C)

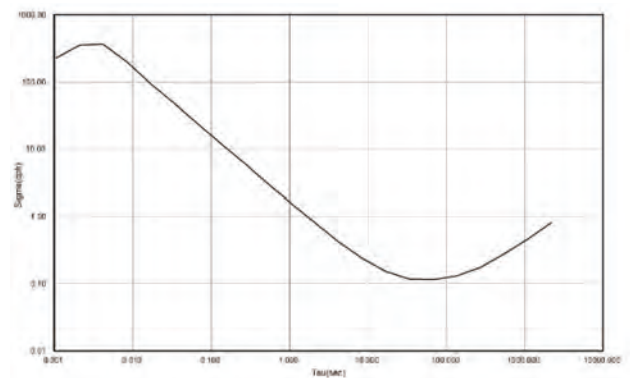

Figure 7.15 CRH03-400 Allan Variance Performance (w.r.t. 25°C)

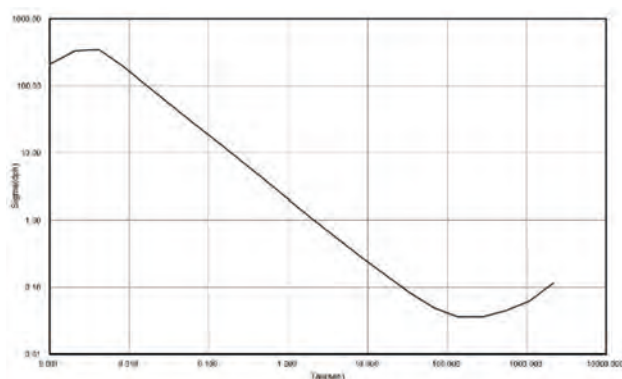

Figure 7.13 CRH03-100 Allan Variance Performance (w.r.t. 25°C)

7.4 Reference Performance Data for Bias for R Version

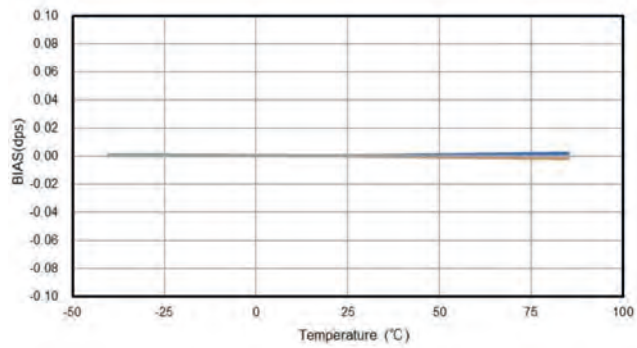

Figure 7.16 CRH03-200UxR Bias Performance (w.r.t. 25°C)

7.5 Reference Performance Data for Scale Factor for R Version

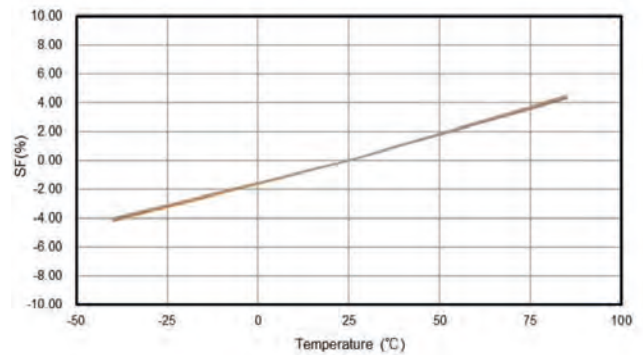

Figure 7.18 CRH03-200UxR SF Performance (w.r.t. 25°C)

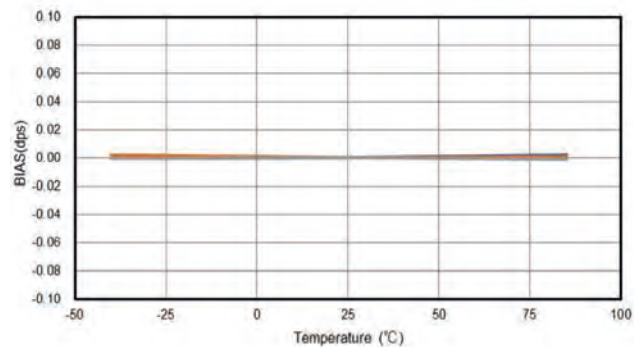

Figure 7.17 CRH03-400UxR Bias Performance (w.r.t. 25°C)

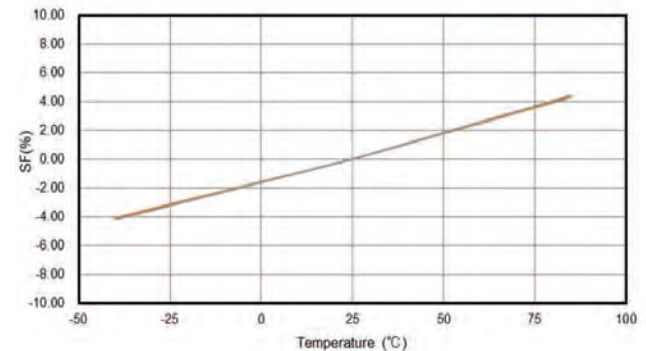

Figure 7.19 CRH03-400UxR SF Performance (w.r.t. 25°C)

Note: Each figure shows 3 data samples. The vertical axis of above figures (Bias data) is half of the production limit.

Note: Each figure shows 3 data samples. The vertical axis of above figures (SF data) is half of the production limit.

7.6 Reference Performance Data for Allan Variance for R Version

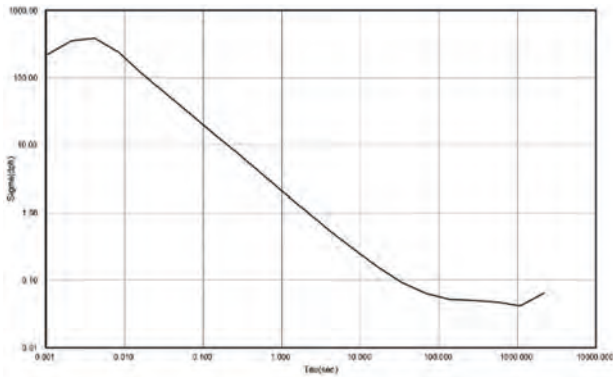

Figure 7.20 CRH03-200UxR Allan Variance Performance (w.r.t. 25°C)

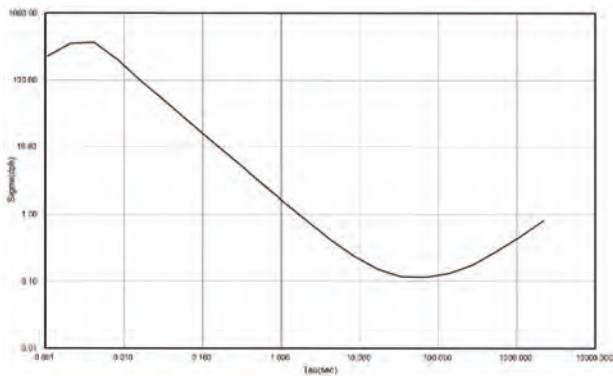

Figure 7.21 CRH03-400UxR Allan Variance Performance (w.r.t. 25°C)

8 Other Information

8.1 Supply Voltage

CRH03's rate output is non-ratiometric meaning that it is independent of supply voltage, provided it is operated within the specified voltage range.

The minimum supply voltage, including ripple and power supply noise, must not fall below 4.85V in order to maintain full performance.

The voltage ramp up speed at power up shall be less than 20ms for voltage ramp up to reach +4.85V. If the voltage ramp up time to +4.85V is greater than 20ms, then the CRH03 may not start up within specification.

8.2 Mating Cable Assembly

An accessory cable (Figure 3.3) is supplied only with the Housed version of CRH03 not the OEM version. For spares, or if an accessory cable is required for the OEM version, refer to the part number details shown in the Ordering Information section.

8.3 Temperature Sensor

The temperature sensor uses a LM20B device, internally connected as shown in Figure 8.1.

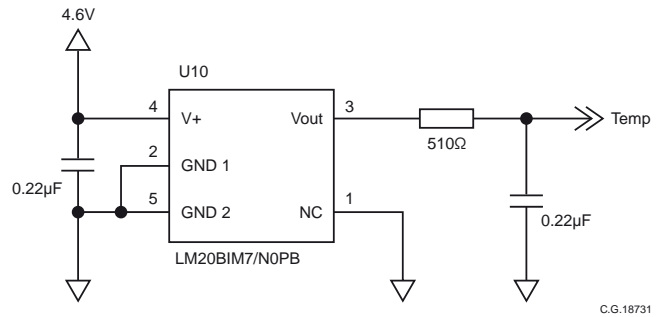

Figure 8.1 Temperature Sensor

The output at 0°C is typically +1.864V with respect to REFL. The temperature coefficient is typically -11.77mV/°C.

The output can be measured with respect to REFL or can be put through a differential input instrumentation amplifier, referenced to the REF pin, in which case the offset at 0°C is typically -0.536V. At +25°C, the output is typically -0.830V with respect to REF. The temperature sensor is not intended for use as a thermometer, since they are not calibrated on the Celsius scale. They are intended only as a temperature reference for thermal compensation techniques.

8.4 Rate and Ref Outputs

Both the Rate and the REF outputs are protected by a series resistor before the output pins. The resistor value is 510Ω.

It is important to take these resistor values into account when calculating the gains of external differential amplifiers. It is also recommended that the REF signal is buffered if it is used as a reference for more than one signal.

It is recommended that the Rate Output is differentially sensed using a precision instrumentation amplifier, referenced to the REF output. A reference Low (0V), REFL is also provided as a ground reference for external ADCs (see Figure 6.1).

The Offset of the instrumentation amplifier should be derived from the host stage (e.g. derived from the ADC REF Voltage) or from the signal ground if the following stage is an analogue stage.

8.5 Frequency Outputs

This is a CMOS Digital (74HC series) compatible digital output running at twice the frequency of the sensor head. It is provided to give an indication of the temperature of the sensor. The nominal frequency is 28kHz with a typical temperature coefficient of -0.8Hz/°C.

The signal is protected with a 1kΩ resistor and it is recommended that it is buffered with a CMOS Schmitt Gate such as 74HC12, or TC7S14F. By monitoring the change in frequency of this signal, an accurate measure of the internal temperature of the sensor can be determined. This can be used for compensation purposes.

An example of measuring the MEMS temperature is to use a precision crystal oscillator (operating at a very high frequency, for example 20, 40 or 60MHz) to measure the frequency of the ring by measuring the time (oscillator clock cycles) to count to a defined number of ring cycles.

8.6 Interaction between Multiple Gyroscopes

The resonant frequency of the gyroscope is nominally 14kHz. If multiple gyroscopes are operated together, there is the possibility of interaction between them, causing a beat frequency to become apparent on their outputs.

In multi-axis applications, it is recommended that different frequency variants are selected (V, L and M) and that the CRH03s are isolated both electrically and mechanically.

Electrical isolation can be achieved by using a separate low drop out linear power regulator for each gyroscope.

Mechanical isolation can be achieved by mounting the gyroscopes as far apart from each other as possible or by the use of anti-vibration or compliant mounts.

8.7 Allan Variance Current Consumption with Temperature

This section shows the typical Allan Variance graphs for the CRH03s at nominally constant ambient temperature.

Figure 8.2 shows a general Allan Variance graph as a guide for calculating bias instability and Angle Random Walk. The Angle Random Walk is calculated as follows:

- A line is drawn tangential to the Allan Variance graph at a -1/2 gradient (on a log-log plot).
- The line is extrapolated to intercept the 1 second correlation point (tau). The value at the intercept point is noted.
- The Angle Random Walk is this value, in units of degrees/hour, divided by 60. In Figure 8.2, the line intercepts the 1 second correlation time at 0.57°/hr, giving an Angle Random Walk of 0.01°/√hr.

The bias instability is at the minimum part of the Allan Variance plot, usually between correlation times of 10s and 100s. In Figure 8.2, the bias instability is approximately 0.05°/hr.

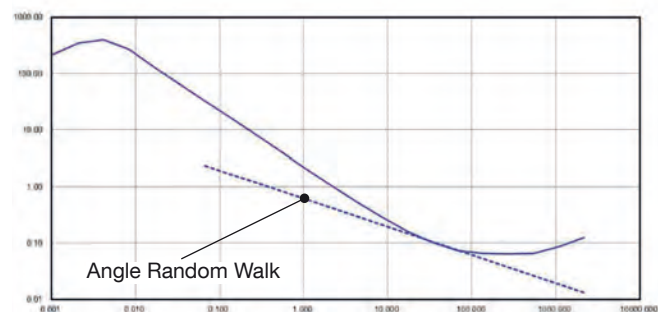

Figure 8.2 Derivation of Angle Random Walk and Bias Instability

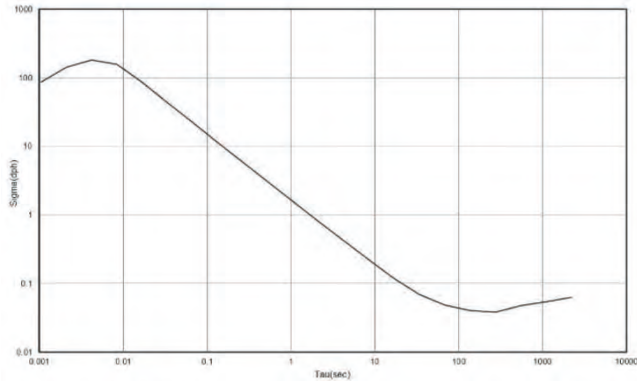

Figure 8.3 CRH03-010 Allan Variance Performance (w.r.t. 25°C)

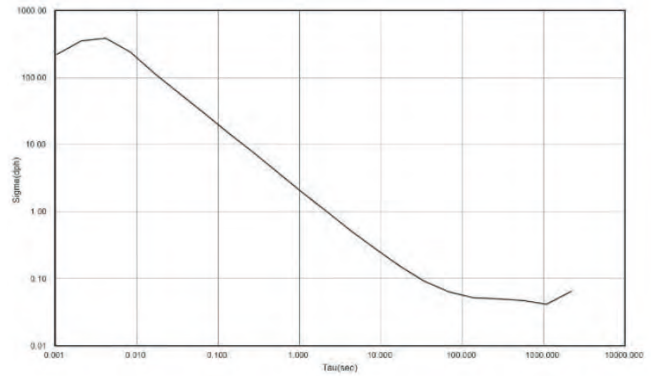

Figure 8.6 CRH03-200 Allan Variance Performance (w.r.t. 25°C)

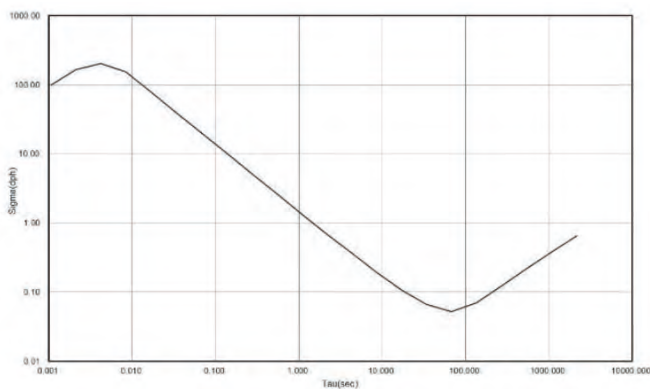

Figure 8.4 CRH03-025 Allan Variance Performance (w.r.t. 25°C)

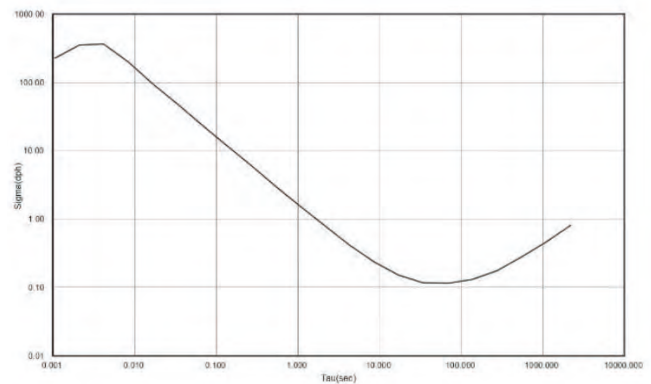

Figure 8.7 CRH03-400 Allan Variance Performance (w.r.t. 25°C)

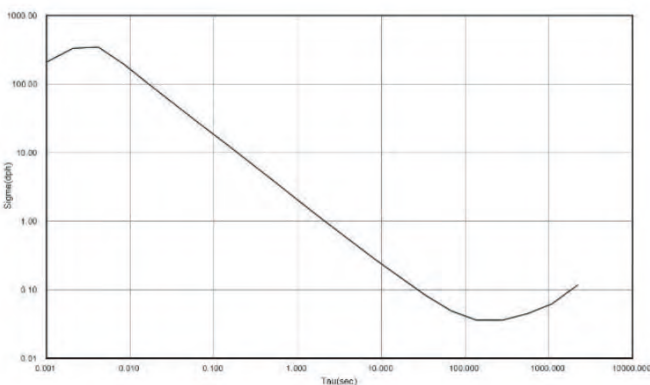

Figure 8.5 CRH03-100 Allan Variance Performance (w.r.t. 25°C)

8.8 Bias Instability

Bias instability is read from the lowest value on the Allan Variance graphs and shown in Section 4.

It is measured using a 24 bit ADC at 25°C.

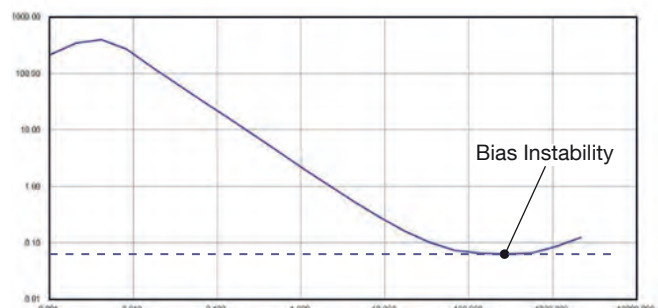

Figure 8.8 Bias Instability

8.9 Rate Output when over Range Input

If CRH03 is operated outside of its specified angular rate range, the sensor will not be damaged but the output will saturate. Once the over range is removed, CRH03 will return to its normal operational state within 2 seconds.

8.10 Soldering

To protect the CRH03 it should not be exposed to temperatures in excess of 100°C.

For re-soldering the following applies:

150°C to 180°C apply heat for < 120 seconds

180°C to 220°C apply heat for < 60 seconds

220°C to 225°C apply heat for < 45 seconds

Maximum temperature 225°C.

8.11 Input Protection

CRH03 does not have reverse or over voltage protection on any input.

8.12 OEM Assembly

The sensor needs to be secured down firmly to achieve the best performance.

Recommend M2 screws (> 12mm) with washers.

Screw head diameter including washer >3.2mm.

Recommend Torque 0.25Nm; Screw U-0212-S1, material of internal thread AC7A-F (anodized).

8.13 Disposal Processing

In the event of scrapping, CRH03 should be disposed of as industrial waste and in accordance with local regulations.

8.14 Notice

Specifications are subject to change without notification for the purpose of product improvement.

9 Glossary of Terms

ADC	Analogue to Digital Converter
ARW	Angular Random Walk
BW	Bandwidth
C	Celsius or Centigrade
DAC	Digital to Analogue Converter
DPH	Degrees Per Hour
DPS	Degrees Per Second
DRIE	Deep Reactive Ion Etch
EMC	Electro-Magnetic Compatibility
ESD	Electro-Static Damage
F	Farads
hr	Hour
HBM	Human Body Model
Hz	Hertz, Cycle Per Second
k	Kilo
MEMS	Micro-Electro Mechanical Systems
mV	Millivolts
NEC	Not Electrically Connected
NL	Scale Factor Non-Linearity
PD	Primary Drive
PP	Primary Pick-Off
RC	Resistor and Capacitor filter
s	Seconds
SF	Scale Factor
SMT	Surface Mount Technology
SOG	Silicon On Glass
SD	Secondary Drive
SP	Secondary Pick-Off
T.B.A.	To Be Announced
T.B.D.	To Be Described
V	Volts
VSG	Vibrating Structure Gyroscope
w.r.t.	With Respect To

CRH03 Series Technical Datasheet

High Performance Analogue Angular Rate Sensor



10 Part Markings

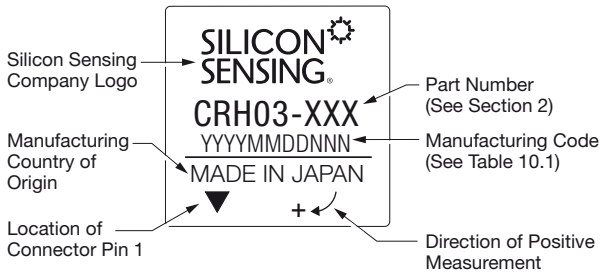

C.G. 18898

Figure 10.1 Part Marking

Data	Code	Range
Manufacture Year	YYYY	0000 - 9999
Manufacture Month	MM	01 - 12
Manufacture Day	DD	01 - 31
Manufacture Number	NNN	001 - 999

Table 10.1 Manufacturing Code

11 Silicon MEMS Ring Sensor (Gyro)

The silicon MEMS ring is 6mm diameter by 100µm thick, fabricated by Silicon Sensing Systems using a DRIE (Deep Reactive Ion Etch) bulk silicon process. The ring is supported in free-space by eight pairs of symmetrical ‘dog-leg’ shaped legs which support the ring from the supporting structure on the outside of the ring.

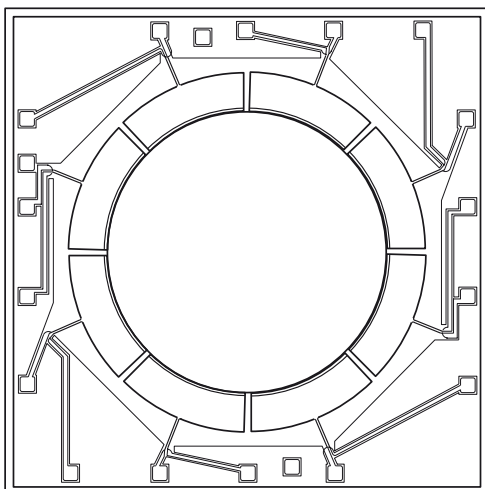

C.G. 18619

Figure 11.1 Silicon MEMS Ring

The bulk silicon etch process and unique patented ring design enable close tolerance geometrical properties for precise balance and thermal stability and, unlike other MEMS gyros, there are no small gaps to create problems of interference and stiction. These features contribute significantly to CRH03’s bias and scale factor stability over temperature, and vibration immunity. Another advantage of the design is its inherent immunity to acceleration induced rate error, or ‘g-sensitivity’.

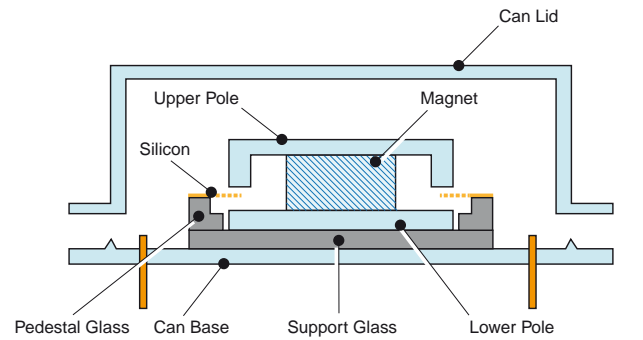

C.G. 18620

Figure 11.2 MEMS VSG3 Sensor

The ring is essentially divided into 8 sections with two conductive tracks in each section. These tracks enter and exit the ring on the supporting legs. The silicon ring is bonded to a glass pedestal which in turn is bonded to a glass support base. A magnet, with upper and lower poles, is used to create a strong and uniform magnetic field across the silicon ring. The complete assembly is mounted within a hermetic can.

The tracks along the top of the ring form two pairs of drive tracks and two pairs of pick-off tracks. Each section has two loops to improve drive and pick-off quality.

One pair of diametrically opposed tracking sections, known as the Primary Drive PD section, is used to excite the $\cos 2\theta$ mode of vibration on the ring. This is achieved by passing current through the tracking, and because the tracks are within a magnetic field causes motion on the ring. Another pair of diametrically opposed tracking sections known as the Primary Pick-off PP section is used to measure the amplitude and phase of the vibration on the ring. The Primary Pick-off sections are in the sections 90° to those of the Primary Drive sections. The drive amplitude and frequency is controlled by a precision closed loop electronic architecture with the frequency controlled by a Phase Locked Loop (PLL), operating with a

Voltage Controlled Oscillator (VCO), and amplitude controlled with an Automatic Gain Control (AGC) system. The primary loop therefore establishes the vibration on the ring and the closed loop electronics is used to track frequency changes and maintain the optimal amplitude of vibration over temperature and life. The loop is designed to operate at about 14kHz.

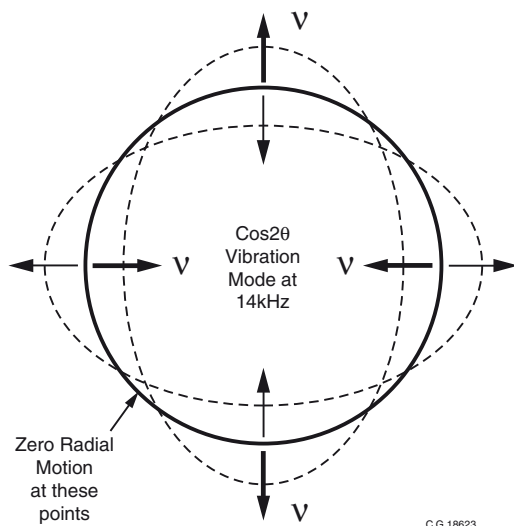

Figure 11.3 Primary Vibration Mode

Having established the $\cos 2\theta$ mode of vibration on the ring, the ring becomes a Coriolis Vibrating Structure Gyroscope. When the gyroscope is rotated about its sense axis the Coriolis force acts tangentially on the ring, causing motions at 45° displaced from the primary mode of vibration. The amount of motion at this point is directly proportional to the rate of turn applied to the gyroscope. One pair of diametrically opposed tracking sections, known as the Secondary Pick-off SP section, is used to sense the level of this vibration. This is used in a secondary rate nulling loop to apply a signal to another pair of secondary sections, known as the Secondary Drive SD. The current applied to the Secondary Drive to null the secondary mode of vibration is a very accurate measure of the applied angular rate. All of these signals occur at the resonant frequency of the ring. The Secondary Drive signal is demodulated to baseband to give a voltage output directly proportional to the applied rate in free space.

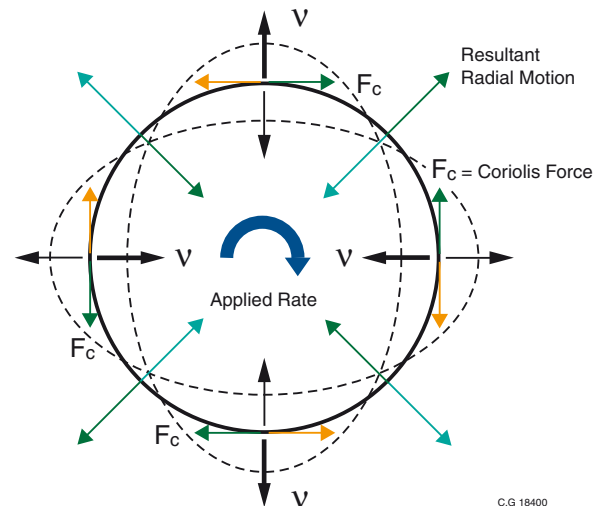

Figure 11.4 Secondary Vibration Mode

The closed loop architecture on both the primary and secondary loops results in excellent bias, scale factor and non-linearity control over a wide range of operating environments and life. The dual loop design, introduced into this new Sensor Head design, coupled with improved geometric symmetry results in excellent performance over temperature and life. The discrete electronics employed in CRH03 ensures that performance is not compromised.

CRH03 Series Technical Datasheet

High Performance Analogue Angular Rate Sensor



Notes

Specification subject to change without notice.
© Copyright 2026
Silicon Sensing Systems Limited
All rights reserved.
Printed in England
Date 08-January-2026

CRH03-00-0100-132 Rev 4
Change no: CO-UK0012908

This document is not controlled under UK regulations but does fall under the definition of uncontrolled technical data (UNCTD).

© Copyright 2026 Silicon Sensing Systems Limited. All rights reserved. Silicon Sensing is an Atlantic Inertial Systems, Sumitomo Precision Products joint venture company.
Specification subject to change without notice.