

LB SERIES

LOAD MEASURING PINS

LB Series Load Measuring Pins can be used alone or as part of a complete measurement system. Magtrol offers a wide range of Load-Force-Weight Transducers in various executions and accuracy classes and our Load Monitoring Units (LMUs) constitute an ideal safe measurement system which continuously checks for overloads and short circuits.

FEATURES

- For overload detection and load measurement from 2.5 kN to 1250 kN (0.28 tf to 140.5 tf).
- Admissible Overload: 150 % of the nominal load.
- Overload at Rupture: up to 500 % of the nominal load.
- Insensitive to external mechanical and chemical effects.
- Ideal for use in hostile environments.
- Temperature-compensated transducers with strain gauges in full-bridge configuration. On request, available with double bridge redundant.
- Simple installation for cost-saving solutions to measurement problems.
- Many options may be added to the lower-cost standard load pin for greater flexibility.
- Can be designed with special dimensions for adaptation to various construction conditions.
- High reliability for strict safety requirements.



Fig. 1: LB210 & LB217 | Load Measuring Pins

DESCRIPTION

MAGTROL Load Measuring Pins are used to measure load and force and provide overload protection. The pins are mounted into machines in place of normal shafts and fitted with strain gauges, allowing them to produce a signal proportional to the measured load. Manufactured in Switzerland, Magtrol's LB2XX Series Load Pins are rugged with high resistance stainless steel and tight construction, designed specifically for use in harsh industrial environments. Available in several standard ranges from 2.5 kN to 1250 kN, these highly ergonomic pins can be used for either new or refitted installations and are adaptable to various conditions.

APPLICATIONS

When forces acting on mechanical constructions are measured, the additional equipment required can often be costly and difficult to install. Magtrol Load Measuring Pins offer an excellent solution since they act as a direct element in the assembly, replacing a non-instrumented pin or shaft. LB2XX Series Load Pins are used for load measuring devices and overload protection on cranes, hoisting gear, elevators and winches, and force measurement for regulation processes in industrial installations and machinery production. Moreover it is an ideal transducer to detect and measure forces in harsh, tropical, offshore, marine and harbor environments.

DESIGN

The Magtrol Load Pin has 2 circular grooves and an axial bore. Inside the central bore, adjacent to the external grooves, the strain gauges are mounted in a full-bridge configuration (double full-bridge for LB 23X models). The positioning and orientation of the strain gauges have been optimized by means of the finite element method (FEM). Any transverse or axial forces, even when acting on any part of the pin, have practically no influence on the measurement signal.

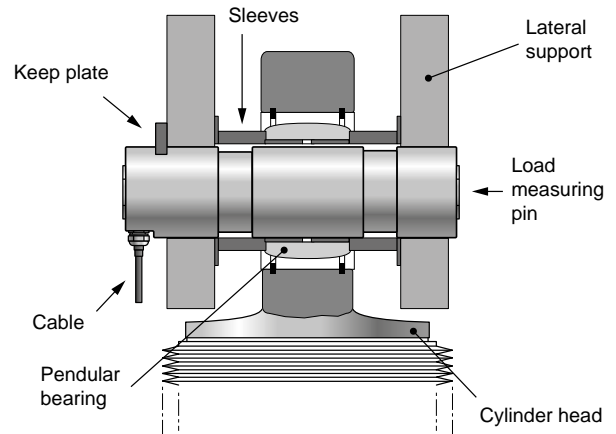

Fig. 2: Mounting example

OPERATING PRINCIPLE

When force is applied to the Load Measuring Pin along its sensitive axis, the effect on the strain gauge bridge results in an output signal proportional to the applied force. The powering of the strain gauge bridge, as well as the amplification of its output signal voltage, is performed by an external amplifier. Depending on the execution, this amplifier allows the monitoring of several levels.

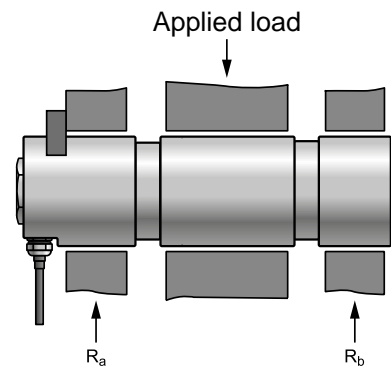
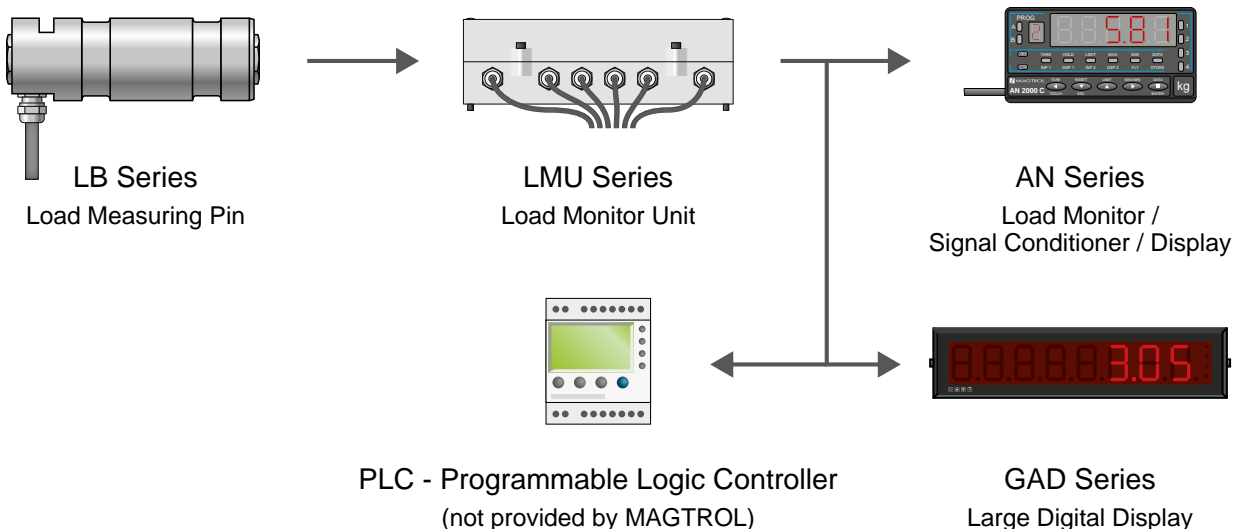

Fig. 3: R_a should equal R_b so that the force is evenly distributed

SYSTEM CONFIGURATION



TECHNICAL DATA - LB 21X SERIES

STANDARD VERSION ^{a)}	LB 210	LB 211	LB 212	LB 213	LB 214	LB 216	LB 217	LB 218	LB 220	LB 221
LOAD MEASUREMENT										
Nominal Load (NL) (Metric) ^{b)}	2.5 kN	5 kN	10 kN	20 kN	50 kN	100 kN	200 kN	500 kN	1 000 kN	1 250 kN
Nominal Load (NL) (US) ^{b)}	0.28 tf	0.56 tf	1.12 tf	2.25 tf	5.62 tf	11.24 tf	22.48 tf	56.2 tf	112.4 tf	140.5 tf
Overload Admissible (% of NL)	150 % (of nominal load without influence on measurement)									
Overload at Rupture (% of NL)	≥500 %							400 %	300 %	
Non-linearity Error ^{b)}	<0.25 %							<0.5 %		<0.5 %
Non-linearity + Hysteresis Error ^{b)}	<0.5 %							<0.8 %		<0.8 %
Repeatability ^{b)}	±0.1 %									

MECHANICAL CHARACTERISTICS & ENVIRONMENT

Operating Principle	Full-bridge strain gauge									
Material	Stainless steel 1.4057									
Lubrication	Not available					Oiler ø4 DIN 3405 D or M10 DIN 3405 A				
Operating Temperature	-25 °C to +80 °C									
Storage Temperature	-55 °C to +125 °C									
Temperature Influence on Zero	±0.02 % / K									
Temperature Influence on Sensitivity	±0.02 % / K									
Fit	G7 / h6									
Angle influence on signal output ^{c)}	According to the cosine function									
Protection Class	IP 66 according to DIN 60529									

ELECTRICAL CHARACTERISTICS & CONNECTIONS

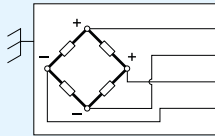
Bridge Impedance Input	400 Ω																			
Bridge Impedance Output	350 Ω																			
Power Supply	5 to 12VDC/AC																			
Zero Adjustment ^{b)}	±1 %																			
Transducer Sensitivities	0.5 mV/V ±3 %			1 mV/V ±3 %				1.8 mV/V ±3 %												
Output	Integrated 3 m, 6 m, 12 m or 20 m cable Radox K-414 (standard) ^{e)}																			
PG Output	Axial, with heat-shrinkable sleeve					Radial, with heat-shrinkable sleeve (standard); Axial, with heat-shrinkable sleeve (optional)														
Wiring Colors	 <table style="margin-left: 20px;"> <tr> <td>Supply +</td> <td>: red</td> </tr> <tr> <td>Supply -</td> <td>: blue</td> </tr> <tr> <td>Signal +</td> <td>: white</td> </tr> <tr> <td>Signal -</td> <td>: green</td> </tr> <tr> <td>Case / Shield</td> <td>: black</td> </tr> </table>										Supply +	: red	Supply -	: blue	Signal +	: white	Signal -	: green	Case / Shield	: black
Supply +	: red																			
Supply -	: blue																			
Signal +	: white																			
Signal -	: green																			
Case / Shield	: black																			
Output Connector (Optional)	Not available					Radial, connector: Souriau 851 02 E 106P50														
Connection Cable Assembly (Optional)	Not available					3 m, 6 m, 12 m or 20 m cable with axial or 90° connector ^{d,e)}														

a) Rating apply to standard load pins only, special models available on request.

b) Of full scale.

c) Variation of the measuring signal due to the angle positioning.

d) Axial connector: Souriau 851 06 JC 10 6S50,
90° connector: Souriau 851 08 EC 106S50.

e) Other longer cables lengths available on request.

DIMENSIONS LB 21X SERIES

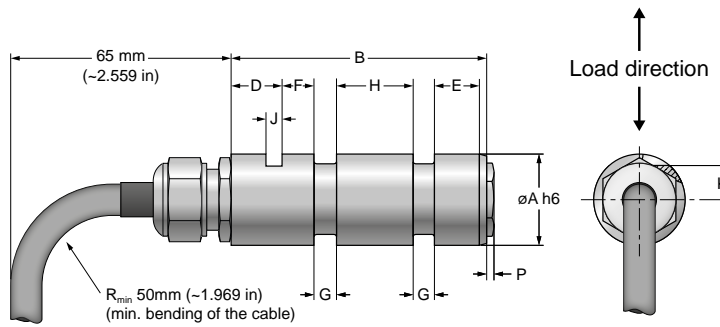

LB 210 - LB 213

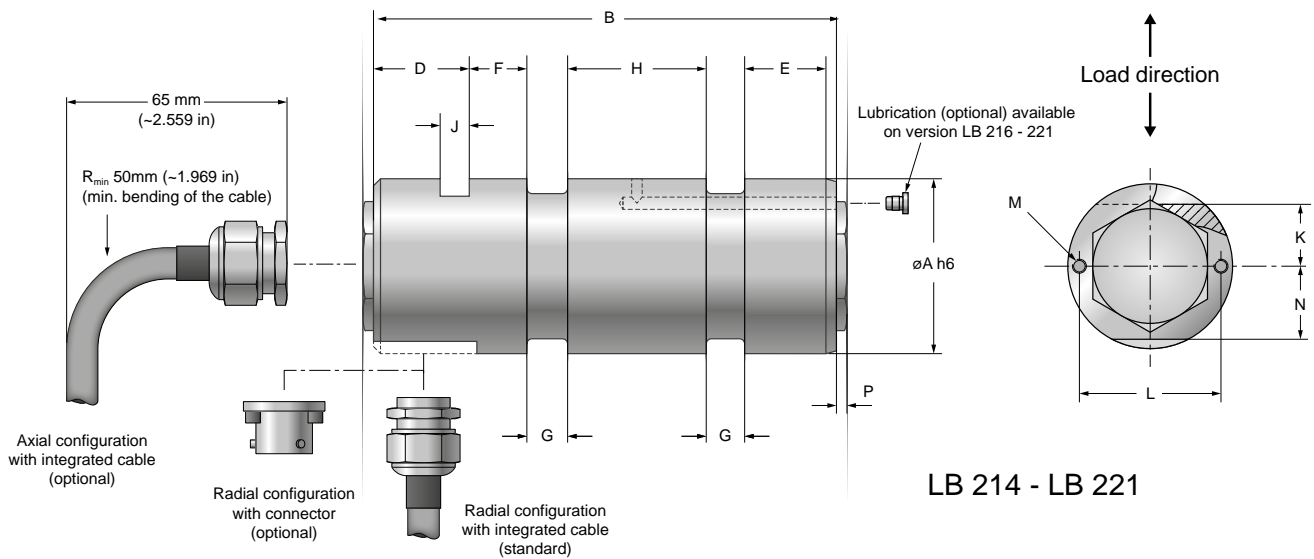

LB 214 - LB 221

NOTE: Original dimensions are in metric units. Dimensions converted to imperial units have been rounded up to 3 decimal places.

MODEL	units	ØA	B	D	E	F	G	H	J	K	L	M	N	WEIGHT	
LB210-213	mm	25 h6	84	18	16	10	7	24	5.2	9	N/A	N/A	N/A	0.2kg	Not available
	in	0.984	3.307	0.709	0.63	0.394	0.276	0.945	0.205	0.354			0.441 lb		
LB214	mm	35 h6	112	25	14	12	12	35	6.3	11.5			16	0.65kg	
	in	1.378	4.409	0.984	0.551	0.472	0.472	1.378	0.248	0.453			0.630	1.433 lb	
LB216	mm	50 h6	161	32	24	18	18	48	10.5	20			21.5	2.0kg	
	in	1.969	6.339	1.26	0.945	0.709	0.709	1.89	0.413	0.787			0.847	4.409 lb	
LB217	mm	65 h6	196	32	26	20	25	65	10.5	22.5			28.5	4.4kg	
	in	2.559	7.717	1.26	1.024	0.787	0.984	2.559	0.413	0.886			1.122	9.700 lb	
LB218	mm	85 h6	258	34	39	35	28	89	10.5	28	32	35	10.6kg		
	in	3.347	10.158	1.339	1.535	1.378	1.102	3.504	0.413	1.102	1.260	1.378	23.369 lb		
LB220	mm	100 h6	347	36	61	55	35	120	10.5	36	35	45	19.2kg		
	in	3.937	13.661	1.417	2.402	2.165	1.378	4.724	0.413	1.417	1.378	1.772	42.328 lb		
LB221	mm	120 h6	347	36	61	55	35	120	12.5	40	35	45	28.4kg		
	in	4.724	13.661	1.417	2.402	2.165	1.378	4.724	0.492	1.575	1.378	1.772	62.611 lb		

a) Oiler ø4 DIN 3405 D or M10 DIN 3405 A

NOTE: 3D STEP files of most of our products are available on our website: www.magtrol.com ; other files are available on request.

TECHNICAL DATA - LB 23X SERIES

STANDARD VERSION ^{a)}	LB 231	LB 232	LB 233	LB 234	LB 235	LB 236	LB 237	LB 238	LB 240	LB 241
--------------------------------	--------	--------	--------	--------	--------	--------	--------	--------	--------	--------

LOAD MEASUREMENT

Nominal Load (Metric) ^{b)}	5 kN	10 kN	20 kN	50 kN	70 kN	100 kN	200 kN	500 kN	1000 kN	1250 kN
Nominal Load (US) ^{b)}	0.28 tf	1.12 tf	2.25 tf	5.62 tf	7.87 tf	11.24 tf	22.48 tf	56.20 tf	112.4 tf	140.5 tf
Overload Admissible (% of NL)	150% of rated load without influence on measurement									
Overload at Rupture (of rated load)	≥500%							400%	300%	
Non-linearity Error ^{b)}						<0.25%				
Non-linearity + Hysteresis Error ^{b)}						<0.4%				
Repeatability ^{b)}						±0.1%				

MECHANICAL CHARACTERISTICS & ENVIRONMENT

Operating Principle	Double full-bridge strain gauge									
Material	Stainless steel 1.4057									
Operating Temperature	-25 °C to +80 °C									
Storage Temperature	-55 °C to +125 °C									
Temperature Influence on Zero ^{b)}	±0.02% / K									
Temperature Influence on Sensitivity	±0.02% / K									
Fit	G7 / h6									
Angle influence on signal output ^{c)}	According to the cosine function									
Protection Class	IP 67 according to DIN 60529									

SAFETY STANDARDS

OIML Class	Not available			R60 D0.1			Not available			
------------	---------------	--	--	----------	--	--	---------------	--	--	--

ELECTRICAL CHARACTERISTICS & CONNECTIONS

Bridge Impedance Input	800 Ω									
Bridge Impedance Output	700 Ω									
Power Supply	5 to 12 VDC/AC									
Zero Adjustment ^{b)}	±1%									
Transducer Sensitivities	0.5 mV/V ±3%			1 mV/V ±3%				1.8 mV/V ±3%		

Output Connector	Axial connector, Souriau 8525 IH 10B06 PNH									
Connection Cable Assembly (option)	3m, 6m, 12m or 20m cable with axial or 90° connector ^{d,e)}									

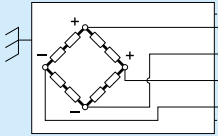
Wiring Colors																									
	<table border="0"> <tr> <td>Supply +</td> <td>:</td> <td>red</td> </tr> <tr> <td>Supply -</td> <td>:</td> <td>blue</td> </tr> <tr> <td>Signal +</td> <td>:</td> <td>white</td> </tr> <tr> <td>Signal -</td> <td>:</td> <td>green</td> </tr> <tr> <td>Case / Shield</td> <td>:</td> <td>black</td> </tr> </table>										Supply +	:	red	Supply -	:	blue	Signal +	:	white	Signal -	:	green	Case / Shield	:	black
Supply +	:	red																							
Supply -	:	blue																							
Signal +	:	white																							
Signal -	:	green																							
Case / Shield	:	black																							

a) Rating apply to standard load pins only, special models available on request.

b) Of full scale.

c) Variation of the measuring signal due to the angle positioning.

d) Axial connector: Souriau 85106JC10 6S50, 90° connector: Souriau 85108EC 106S50.

e) Other longer cables lengths available on request.

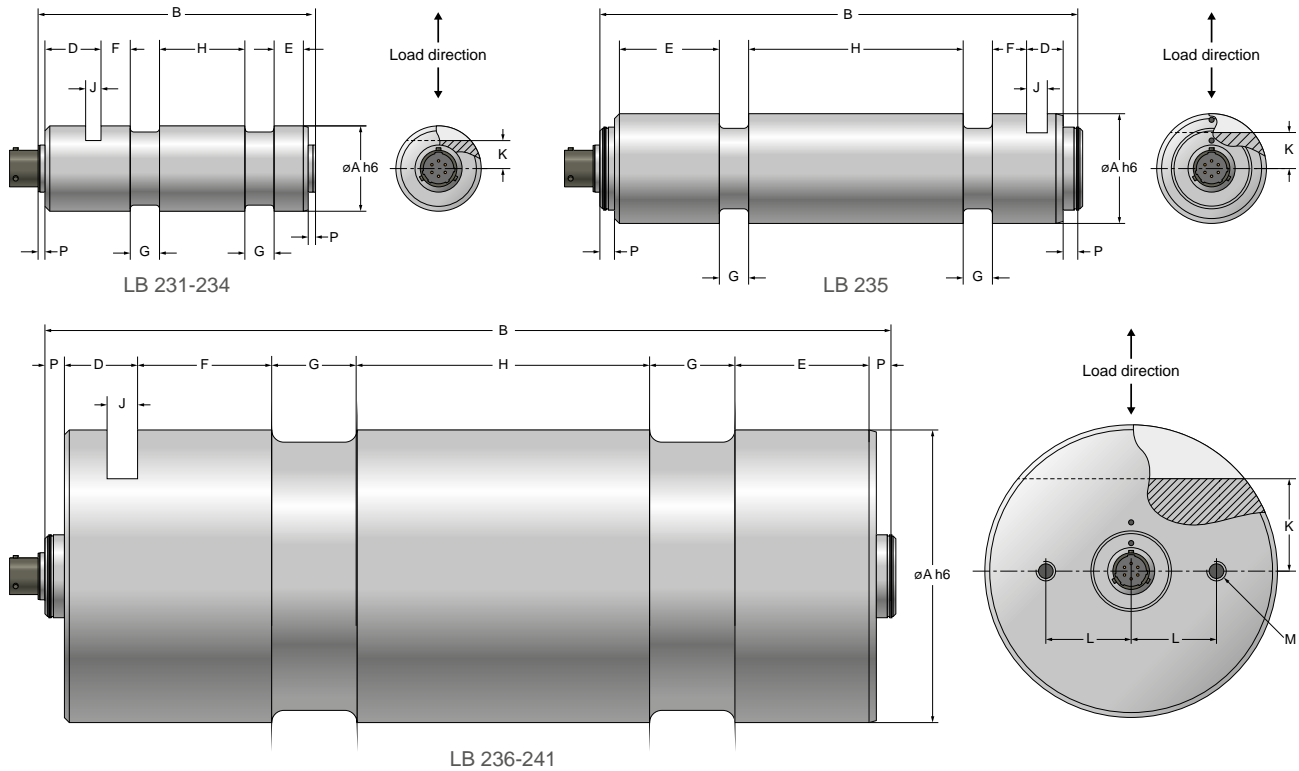
DIMENSIONS LB 23X SERIES

NOTE: Original dimensions are in metric units. Dimensions converted to imperial units have been rounded up to 3 decimal places.

MODEL	UNITS	ØA	B	D	E	F	G	H	J	K	L	M	P	WEIGHT		
LB231-233	mm	25h6	86	16	14	10	7	24	5.2	9	N/A	N/A	3	0.2 kg		
	in	0.984	3.386	0.630	0.551	0.394	0.276	0.945	0.205	0.354			0.118	0.441 lb		
LB234	mm	35h6	114	23	12	12	12	35	6.3	11.5			3	0.65 kg		
	in	1.378	4.488	0.906	0.472	0.472	0.472	1.378	0.248	0.453			0.118	1.433 lb		
LB235	mm	45h6	196	15	41	14	12	88	8.5	16			6	1.8 kg		
	in	1.772	7.717	0.591	1.614	0.551	0.472	3.465	0.335	0.630			0.236	3.968 lb		
LB236	mm	50h6	165	28	20	18	18	48	10.5	20			6	2 kg		
	in	1.969	6.496	1.102	0.787	0.709	0.709	1.890	0.413	0.787			0.236	4.409 lb		
LB237	mm	65h6	200	28	22	20	25	65	10.5	22.5			6	4.4 kg		
	in	2.559	7.874	1.102	0.866	0.787	0.984	2.559	0.413	0.886			0.236	9.700 lb		
LB238	mm	85h6	262	30	35	35	28	89	10.5	28			25	M6	6	10.6 kg
	in	3.346	10.315	1.181	1.378	1.378	1.102	3.504	0.413	1.102			0.984	0.236	23.369 lb	
LB240	mm	100h6	351	30	55	55	35	120	10.5	36			35	M8	8	19.2 kg
	in	3.937	13.819	1.181	2.165	2.165	1.378	4.724	0.413	1.417			1.378		0.315	42.329 lb
LB241	mm	120h6	351	30	55	55	35	120	12.5	40			35		8	28.4 kg
	in	4.724	13.819	1.181	2.165	2.165	1.378	4.724	0.492	1.575			1.378		0.315	62.611 lb

NOTE: 3D STEP files of most of our products are available on our website: www.magtrol.com ; other files are available on request.

ACCESSORIES LB 2XX SERIES

CABLE ASSEMBLIES

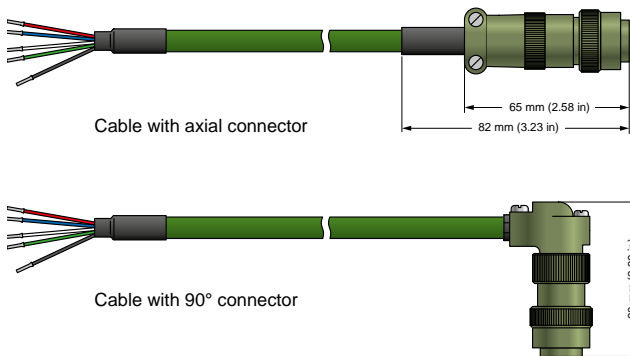

CABLE ASSEMBLY ORDERING INFORMATION

ORDERING NUMBER	EH 13	-	/ 0	-	X
8 : Axial connector					
9 : 90° connector					
1 : Cable length 3 m					
2 : Cable length 6 m					
3 : Cable length 12 m					
4 : Cable length 20 m ^{a)}					

a) Other longer cables lengths available on request.

PIN CONFIGURATION

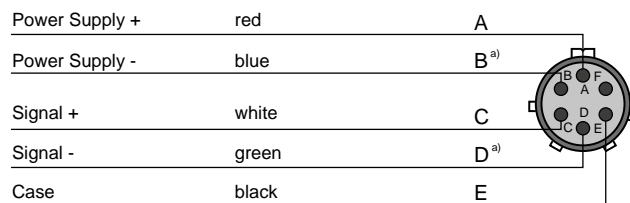

a) Pins B and D are connected together. This feature allows the user to cancel the voltage drop error due to the supply current on the cable (4-wire measurement).

COUNTER CONNECTOR

Axial connector	PN 957-11-08-0030
90° connector	PN 957-11-08-0029

ORDERING INFORMATION LB 21X SERIES

STANDARD MODEL / ORDERING NUMBER	LB 2	--	/ 0 0	-
10, 11, ..., 13 : Model LB21X (Connection: PG Axial)				
14, 16, ..., 21 : Model LB21X (Connection: PG Radial)				
OPTIONAL MODEL / ORDERING NUMBER	LB 2	--	/ - -	-
14, 16, ..., 21 : Model LB21X (Connection: PG Radial)				
0 : Without Lubrication (standard)				
1 : With Lubrication (available only on LB216-221)				
Electrical Connection:				
0 : PG Radial (standard)				
1 : PG Axial				
2 : Radial Connector				
Connection cable:				
0 : Connector (axial or radial)				
1 : Cable length 3 m				
2 : Cable length 6 m				
3 : Cable length 12 m				
4 : Cable length 20 m ^{a)}				

Example: LB218 Load Measuring Pin (Optional Model) with lubrication, PG Axial and 6 m cable would be ordered as follows: LB218/112.

LB212 Load Measuring Pin (Standard Model) with 3 m cable would be ordered as follows: LB212/001.

a) Other longer cables lengths available on request.

ORDERING INFORMATION LB 23X SERIES

ORDERING NUMBER	LB 2	--	/ XXX
31, 32, ... 41 : Model LB23X			

Example: LB237 Load Measuring Pin would be ordered as follows: LB237/XXX.

SYSTEM OPTIONS & ACCESSORIES

MB-02 SERIES - MINIATURE LOAD PINS



Fig. 4: Miniature Load Pin **MB-02-10-10-2**

Magtrol Load Measuring Pins are used to measure load and force and provide overload protection. The pins are mounted into machines in place of normal shafts and fitted with strain gauges, allowing them to produce a signal proportional to the measured load.

Manufactured in Switzerland, Magtrol's MB-02 Series Miniature Load Pins are rugged with high resistance stainless steel and tight construction, designed specifically for use in harsh industrial environments.

The compact design as well as the high protection class give this sensor an excellent aptitude for the measurement and monitoring of forces and overloads on mechanical compact applications, as well as in harsh environments.

AN SERIES - LOAD MONITOR DISPLAY WITH INTEGRATED SIGNAL CONDITIONER



Fig. 5: **AN 1500 M** - Load Monitor Display with integrated signal conditioner

The AN 1500 M Load Monitor is designed to process and display signals coming from various types of transducers (weight, load, pressure, torque, etc.) that use standard strain-gauge bridges.

The basic instrument is a soldered assembly composed of a main board, a tri-color programmable display and a power circuit. Standard features include the reading of the input variable as well as remote hold, reading and memorization of max and min values (peak / valley), tare and reset function.

LMU SERIES - LOAD MONITORING UNIT



Fig. 6: **LMU 216** - Load Monitoring Unit

Magtrol's Load Monitoring Units are used for measuring load, force and weight from signals generated by strain gauge transducers. Specifically designed for use with Magtrol's Load Measuring Pins and Load-Force-Weight Sensors, the LMU Series provides excitation voltage while conditioning the bridge output signal.

Each unit contains DIP-switches and jumpers for greater flexibility and complete adaptability. User-defined alarm limits can be configured into the unit, which when combined with our sensors, provides a safe and rugged measurement system that continuously monitors for short-circuits and interrupted signal lines. Magtrol LMUs are specially designed for use in harsh environments and are suitable for crane security systems.

GAD SERIES - LARGE DIGITAL DISPLAYS



Fig. 7: **GAD 6** - digits height 102mm - Large Digital Display

These high quality, large character digital displays can be used for crane weight display, process weight display, and all other remote weighing applications. They use microprocessor based technology for high reliability and have a non-volatile memory to store all the calibration data.

Magtrol Large Digital Displays are used with Load Monitoring Units (LMUs) or signal conditioners (AN Series), as part of a complete measurement system. Magtrol load measuring pins, which measure load and force to provide overload protection, are available for a wide range of Load-Force-Weight, and in various executions and accuracy classes. Combined, these products constitute an ideal safe measurement system for continuous overload monitoring.