

# LCM Series

## Tension and Compression Sensor Family Manual

Sensor Solutions Source

Load · Torque · Pressure · Multi-Axis · Calibration · Instruments · Software

[www.futek.com](http://www.futek.com)

**DSPM** Industria®  
sensori & trasduttori

Via Paolo Uccello 4 - 20148 Milano

Tel +39 02 48 009 757 Fax +39 02 48 002 070 [info@dspmindustria.it](mailto:info@dspmindustria.it) [www.dspmindustria.it](http://www.dspmindustria.it)

## Table of Contents

<a href="#">Mechanical Installation</a> . . . . .	3	<a href="#">Shield Usage and Connections</a> . . . . .	8
<a href="#">Mounting and Installation</a> . . . . .	4	<a href="#">Calibration</a> . . . . .	8
<a href="#">Maximum Installation Torque</a> . . . . .	5	<a href="#">Troubleshooting</a> . . . . .	9
<a href="#">Cable Care and Routing</a> . . . . .	6	<a href="#">Further Support Resources</a> . . . . .	11
<a href="#">Electrical Installation</a> . . . . .	7		

## Mechanical Installation

The following precautions should be observed to avoid damage to the LCM sensor during installation and usage.

- Avoid conditions that exceed the sensor's spec sheet IP rating.

1. Do not pull on or carry sensor by cable.

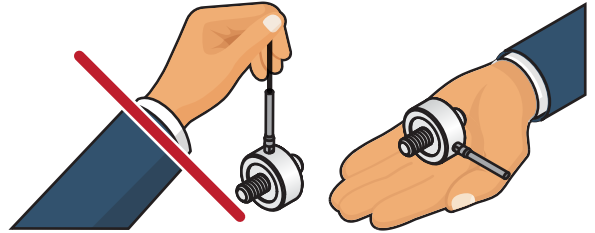

2. Avoid over torque during installation.

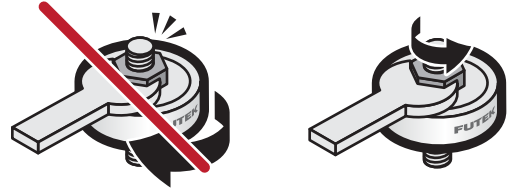

3. Monitor sensor output for effects on zero output during installation to avoid damage.



4. Install in a dry, clean environment.



5. Avoid utilizing sensor cover to twist sensor into place.

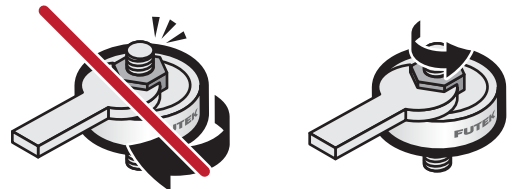

## Mounting and Installation

- Refer to the sensor spec sheet for thread information and proper load cell orientation to maximize performance and limit cable interference.

### MAXIMUM MOMENTS AND OFF-AXIS LOADING

- Use extraneous load information to determine if the sensor can withstand any unavoidable off-axis loads and moments. Extraneous load information can be found at: <http://www.futek.com/extraneous-load-factor>
- An extraneous load how-to-guide can be found at: [http://www.futek.com/files/pdf/Extraneous\\_Load\\_Factors/How\\_To\\_Calculate\\_Extraneous\\_Loads.pdf](http://www.futek.com/files/pdf/Extraneous_Load_Factors/How_To_Calculate_Extraneous_Loads.pdf)

1. Load must be in-line and centered.

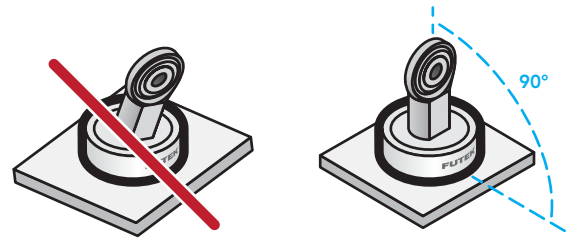

2. Loading must be flat and in-line when compensating linkages are not used



3. Support sources must be flat and in-line

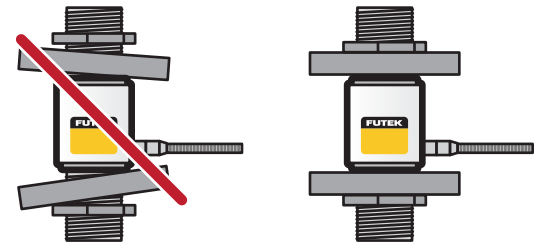

4. A locknut, or jam nut, can be used to help limit the torque into the sensor as well as improve the load distribution in the thread joint which in turn improves the sensor's repeatability.

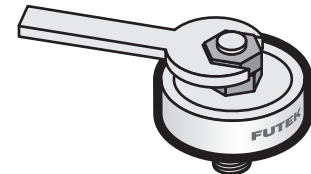

 Non-loading surface, do not contact

 Active End

 Fixed End

+ Output (tension)

- Output (compression)

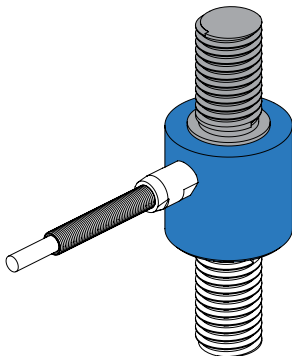
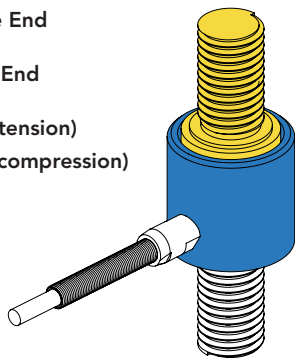

### Sensor Solution Source

Load · Torque · Pressure · Multi-Axis · Calibration · Instruments · Software

[www.futek.com](http://www.futek.com)

**DSPM Industria**  
sensori & trasduttori

Via Paolo Uccello 4 - 20148 Milano

Tel +39 02 48 009 757 Fax +39 02 48 002 070 [info@dspmindustria.it](mailto:info@dspmindustria.it) [www.dspmindustria.it](http://www.dspmindustria.it)



U.S. Manufacturer

MAXIMUM INSTALLATION TORQUE		
MODEL	CAPACITY	MAXIMUM BOLT TORQUE (lbf-in)
LCM100	1000g	11.7
	5 lb	14.6
	10 lb	14.6
	25 lb	17.0
LCM200	250 lb	40.5
	500 lb	40.5
	1000 lb	49.3
LCM300	50 lb	154.0
	100 lb	154.0
	250 lb	154.0
	500 lb	154.0
	1000 lb	154.0
LCM325	3000 lb	326.9
LCM350	5000 lb	651.4
LCM375	10000 lb	1307.7
LCM425	5000 lb	1307.7
LCM525	10000 lb	1757.7
	20000 lb	4473.7
LCM550	50000 lb	22973.0

## Cable Care and Routing

- Cable material type and length can be found online in the sensor description page.

1. Use extra care in handling for smaller gauged cables to avoid knotting and cable stress.

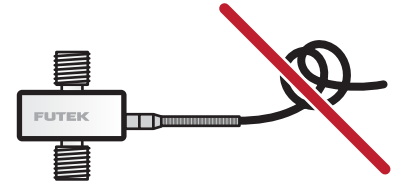

2. Avoid stress and movement on cable to avoid damage.

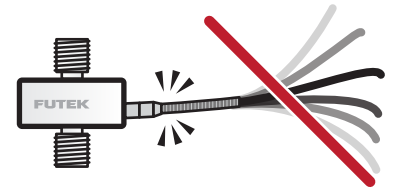

3. Properly secure sensor cable to limit cable movement influence

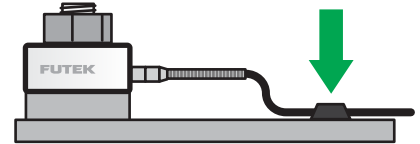

4. Avoid bending the strain relief. Bends in the cable should not exceed a radius of 10 times the diameter of the sensor cable for dynamic, or moving, applications. When permanently routing a cable in a static installation, the minimal bend radius should not fall below 2-3 times the diameter of the cable.

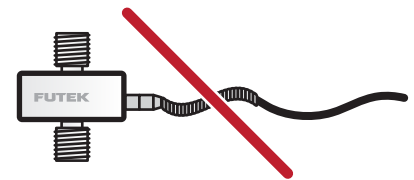

## Electrical Installation

### WIRING AND CONNECTIONS

- The LCM load cell series utilizes a four-wire bare lead connection, a six-wire bare lead connection, a four-pin Lemo connection, or a six-pin Bendix connection.
- Standard four-wire connections are +Excitation, -Excitation, +Signal, and -Signal. The standard coloring code for the above listed connections are Red, Black, Green, and White.
- Six-wire connections offer additional +Sense and -Sense connections or TEDS data and TEDS return connections. Additional connection standard colors are Orange and Blue.

LCM EXCITATION POWER LEVELS	
SENSOR FAMILY	MAX. EXCITATION
LCM100	7 V
LCM200	15 V
LCM300	15 V
LCM325	18 V
LCM350	18 V
LCM375	18 V
LCM525	18 V
LCM550	18 V

### WC1 STANDARD 4-WIRE

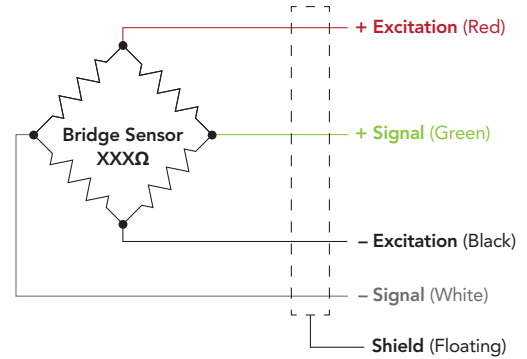

### WC1s STANDARD 4-WIRE

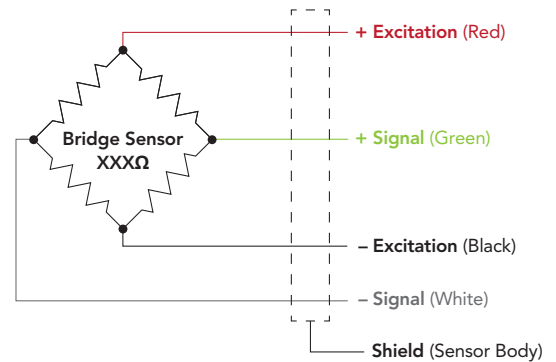

### CC1

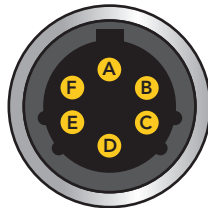

Sensor Receptacle View

BENDIX 6-PIN		
PIN	COLOR	DESCRIPTION
A	Red	+ Excitation
B	Black	- Excitation
C	Green	+ Signal
D	White	- Signal
E	Orange	+ Sense
F	Blue	- Sense

## Shield Usage and Connections

- Cable shielding should be grounded on one end, either the sensor side or instrument side to avoid ground loops.
- A shield connection listed as floating on a sensor's spec sheet means the cable shield is not connected on the sensor side and may be connected on the instrument side to ground.
- Shield connections are located on the sensor's spec sheet.

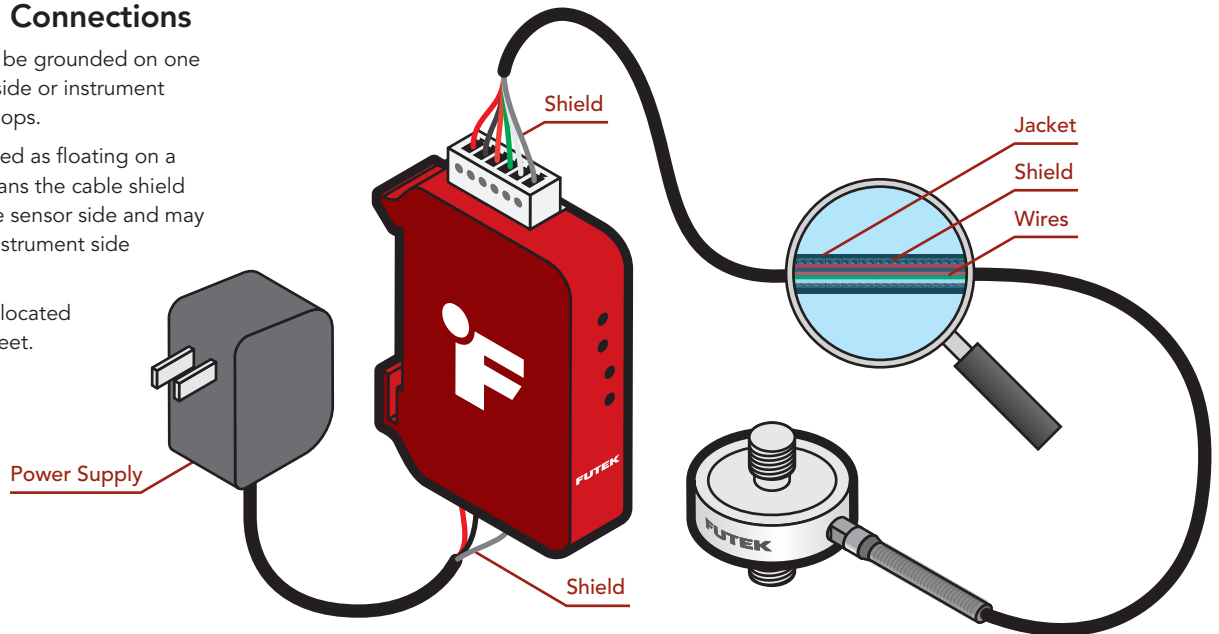

## Calibration

- A yearly calibration is recommended. But verification and calibration period shall be defined based on application, conditions, endurance and usage.
- FUTEK offers NIST calibrations as well as A2LA certified calibrations for total uncertainty.
- For more information on available calibrations visit FUTEK calibration web page at: <http://www.futek.com/calibration-services.aspx>
- For recalibration orders visit the FUTEK recalibration page at: <http://www.futek.com/recalibration.aspx>
- An online summary of calibration results is available at: <http://www.futek.com/calibrationData.aspx>

## SHUNT

A shunt is an external resistance applied across two points on the load cell's Wheatstone bridge to generate a known, fixed output from the sensor.

Shunt results can be used to set up instruments as well as compare changes to the load cell output over time and usage.

When selecting the appropriate shunt resistance for your load cell, we recommend a resistance that generates an output of about 80% of the sensor's rated output. It is important to have a shunt resistance that results in an output that is less than the full output of the load cell.

An online shunt calculator can be found at <http://www.futek.com/shuntcalc.aspx> to find a resistance that will generate a certain shunt output level, or to estimate the output for a known shunt resistance.

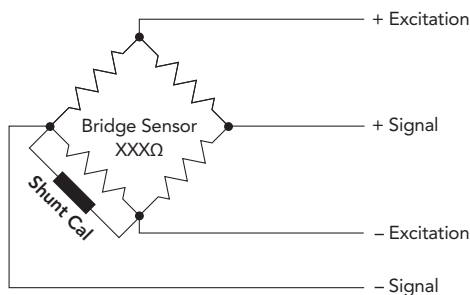

## TEDS

Transducer Electronic Data Sheet (TEDS) standard is available for FUTEK sensors and is utilized by select FUTEK instruments.

Through the use of TEDS load cell calibration information can be stored with sensor, or sensor cable, for use with TEDS capable instruments.

FUTEK utilizes the Bridge Sensor template 33 for the LCM family.

The following FUTEK instruments are TEDS and LSB compatible:



**IPM650**  
Panel Mount Display



**IHH500**  
Handheld Instrument

### Sensor Solution Source

Load · Torque · Pressure · Multi-Axis · Calibration · Instruments · Software



## Troubleshooting

When troubleshooting, we recommend that the sensor be removed from any fixtures. In order to confirm that that sensor is operating correctly, we suggest placing the sensor on a firm surface, and to apply a known load.

We also recommend using a volt meter with a clean power supply to confirm the sensor is operating correctly.

SYMPTOM	POSSIBLE CAUSE	CHECK	REPAIRABILITY
<b>High zero output</b>	<ul style="list-style-type: none"> <li>• Sensor is under preload</li> <li>• Sensor has been overloaded from too much load, off axis load, or moment.</li> </ul>	<ul style="list-style-type: none"> <li>• Fixtures or bolting stress for causes of pre-load.</li> <li>• Loading and support placement for off axis loads.</li> <li>• Avoid excessive moments during installation.</li> </ul>	<ul style="list-style-type: none"> <li>• Overload shift would not be repairable.</li> <li>• If zero offset is stable it may be possible to use sensor by use of Tare or subtracting zero from sequential readings.</li> </ul>
<b>Non-responsive zero output</b>	<ul style="list-style-type: none"> <li>• Sensor or instrument is not powered.</li> <li>• Sensor is not properly connected.</li> <li>• Load is not displaced properly onto sensor.</li> <li>• Sensor is not supported correctly and not allowing deflection to occur to measure load.</li> <li>• Internal disconnect or short.</li> </ul>	<ul style="list-style-type: none"> <li>• Power and wiring to sensor and instrument.</li> <li>• Sensor bridge resistance for possible opens or shorts.</li> <li>• Perform continuity test on cable.</li> <li>• Load is placed correctly on sensor loading surface.</li> <li>• Sensor loading surface is not obstructed or supported and able to flex under load.</li> <li>• Sensor support is not giving while sensor is loaded.</li> </ul>	<ul style="list-style-type: none"> <li>• Internal disconnections or shorts would not be available for repair.</li> <li>• Sensor cable repair may be available if disconnect or short is not too close to sensor.</li> </ul>
<b>Non-responsive high output</b>	<ul style="list-style-type: none"> <li>• Sensor is disconnected from instrument.</li> <li>• An opening has occurred in sensor or cable connection.</li> <li>• Sensor has been overloaded and deformed causing permanent high stress on internal gauges.</li> <li>• Fixture, applied load, or mounting is causing a high pre-load on sensor.</li> </ul>	<ul style="list-style-type: none"> <li>• Power and wiring to sensor and instrument.</li> <li>• Sensor bridge resistance for possible opens or shorts.</li> <li>• Perform continuity check on cable.</li> <li>• Sensor zero output to see if sensor returns to zero or has a high zero load output due to overloading.</li> <li>• Remove load and loosen mounting bolts or fixtures to check if sensor is being preloaded.</li> </ul>	<ul style="list-style-type: none"> <li>• Overload shift would not be repairable.</li> <li>• Internal disconnections or shorts would not be available for repair.</li> <li>• Sensor cable repair may be available if disconnect or short is not too close to sensor.</li> </ul>
<b>Incorrect output for applied load</b>	<ul style="list-style-type: none"> <li>• Load is not applied correctly to sensor loading surface or is off axis.</li> <li>• Fixtures are not secure or obstruct loading.</li> <li>• Sensor loading surface is not able to deflect with applied load.</li> <li>• Sensor support is not ridged and firm.</li> <li>• Incorrect sensor output is utilized.</li> </ul>	<ul style="list-style-type: none"> <li>• Placement of load on sensor.</li> <li>• Fixtures are not impeding ability to load.</li> <li>• Support surface is not giving with applied load.</li> <li>• Calibration verified outputs are being used.</li> </ul>	<ul style="list-style-type: none"> <li>• Recalibration is available for confirmation of sensor performance.</li> </ul>

SYMPTOM	POSSIBLE CAUSE	CHECK	REPAIRABILITY
<b>Zero output drift</b>	<ul style="list-style-type: none"> <li>• Unstable power supply, or noisy power supply, to sensor.</li> <li>• Sensor exposed to temperature change.</li> <li>• Sensor exposed to pre-load from fixture or mounting.</li> <li>• Sensor exposed to liquid or humidity.</li> </ul>	<ul style="list-style-type: none"> <li>• Stability of power supply and noise levels.</li> <li>• For temperature changes or unevenly distributed temperature changes.</li> <li>• Possible loose fixtures and bolts</li> </ul>	<ul style="list-style-type: none"> <li>• Internal damage from liquid exposure is not repairable.</li> <li>• Recalibration is available for confirmation of sensor performance.</li> </ul>
<b>Creep in output while under load</b>	<ul style="list-style-type: none"> <li>• Load or fixtures are not stable.</li> <li>• Power supply is unstable or noisy.</li> <li>• Sensor is exposed to temperature change.</li> <li>• Sensor support is not rigid and firm.</li> <li>• Sensor exposed to liquid or humidity.</li> </ul>	<ul style="list-style-type: none"> <li>• Stability of power supply and noise levels.</li> <li>• Fixtures for stability.</li> <li>• For temperature changes or unevenly distributed temperature changes.</li> <li>• Confirm support surfaces are not giving while under load.</li> </ul>	<ul style="list-style-type: none"> <li>• Internal damage from liquid exposure is not repairable.</li> <li>• Recalibration is available for confirmation of sensor performance.</li> </ul>
<b>Noisy or unstable output</b>	<ul style="list-style-type: none"> <li>• Power supply is noisy.</li> <li>• Load is not stable.</li> <li>• Sensor or cable is placed close to high power equipment.</li> <li>• Sensor or instrument is exposed to ground loop with other equipment grounds.</li> </ul>	<ul style="list-style-type: none"> <li>• Power supply stability.</li> <li>• Load is stable and fixtures are secure.</li> <li>• Reroute cables away from high power equipment.</li> <li>• Confirm wiring and grounds are not connected to unintended equipment ground.</li> </ul>	<ul style="list-style-type: none"> <li>• There are no active electronics in a load cell, such as capacitors or IC chips that may contribute to noise.</li> </ul>



## Further Support Resources

- More information about our LCM sensor series can be found online at the FUTEK website. <http://www.futek.com/lcm/overview.aspx>
- Support information for FUTEK instruments can be found online at: <http://www.futek.com/manuals.aspx>
- A one year recalibration is recommended. But verification and calibration period shall be defined based on application, conditions, endurance and usage. Calibration data may be available online at <http://www.futek.com/calibrationData.aspx>
- To send in your sensor or system for recalibration visit our FUTEK calibration web page at: <http://www.futek.com/recalibration.aspx>
- FUTEK Technical Support may be reached at: <http://www.futek.com/contact.aspx?form=technical>
- To send in your sensor or system for evaluation and repair visit our FUTEK RMA web page at: <http://www.futek.com/contact.aspx?form=repair>
- FUTEK contact information can be found online at: <http://www.futek.com/contact>
- Warranty information can be found online at <http://www.futek.com/remWarranty.aspx>

Drawing Number: EM1038